



## VEGETABLE PEELER, 5KG

**Model: T5S**

**Article no: 601218**

**Power supply: 230V 1Ph ~50-60Hz**

The peeling machine is to be used as equipment for vegetables preparation allowing to carry out different activities with the same tool like washing, scrubbing and peeling. It is made of stainless steel with a transparent removable lid in special high resistant plastic. The rotating plate is covered with a special abrasive lava stone material guaranteeing a high quality finish to the peeled vegetables and a practically unlimited lifespan.

When peeling is finished the products are channelled out through the hatch when manually activating the disc rotation.

An interlocking safety magnetic devices will stop the machine from operating when the lid or door is opened. Simple control panel with ON/OFF buttons and timer.

### MAIN FEATURES

- Supplied with an abrasive plate.
- Removable rotating plate.
- Easy to empty peeled products through the chute.
- Magnetic detectors will stop the machine from operating when the lid and/or door are opened.
- Suitable for 30-100 meals per service.

T5S, 601218  
17-01-24 (07:31)

## TECHNICAL DATA

T5S, 601218, 17-01-24 (07:31)

<b>Model Number Specific</b>	T5S
<b>Voltage (V)</b>	230
<b>Phase</b>	1
<b>Frequency (Hz)</b>	50-60
<b>Loading (kW)</b>	0,12
<b>IP Class</b>	34
<b>Capacity (kg)</b>	5
<b>Capacity, max (kg/h)</b>	80
<b>Width, net (mm)</b>	314
<b>Depth, net (mm)</b>	485
<b>Height, net (mm)</b>	450
<b>Weight, net (kg)</b>	17
<b>Weight, gross (kg)</b>	21
<b>Volume, net (m3)</b>	0,1
<b>Volume, gross (m3)</b>	0,13
<b>Connection Cable, length (m)</b>	1
<b>Plug type</b>	Schuko
<b>Cold water inlet, diameter (")</b>	1/2
<b>Meals per service (pcs)</b>	100
<b>Noise level &lt;(dB)</b>	72

## INCLUDED IN DELIVERY

653182 - Abrasive peeling disc for 5 kg veg. peeler

Loipart AB (HQ), **Sweden**  
Tel. +46 313 920 100, loipart@loipart.se

LMG Finland oy, **Finland**  
+358 40 664 6680, lmg@lmg.fi



Loipart USA inc, **USA**  
Tel. +1 954 530 5276, loipartusa@loipart.com

Loipart SEA Pte Ltd, **Singapore**  
Tel. +65 674 99 100, contact@loipart.sg

Visit us at [www.loipart.com](http://www.loipart.com)

# DIMENSIONS

Model: T5S Rev. 1

FRONT

SIDE

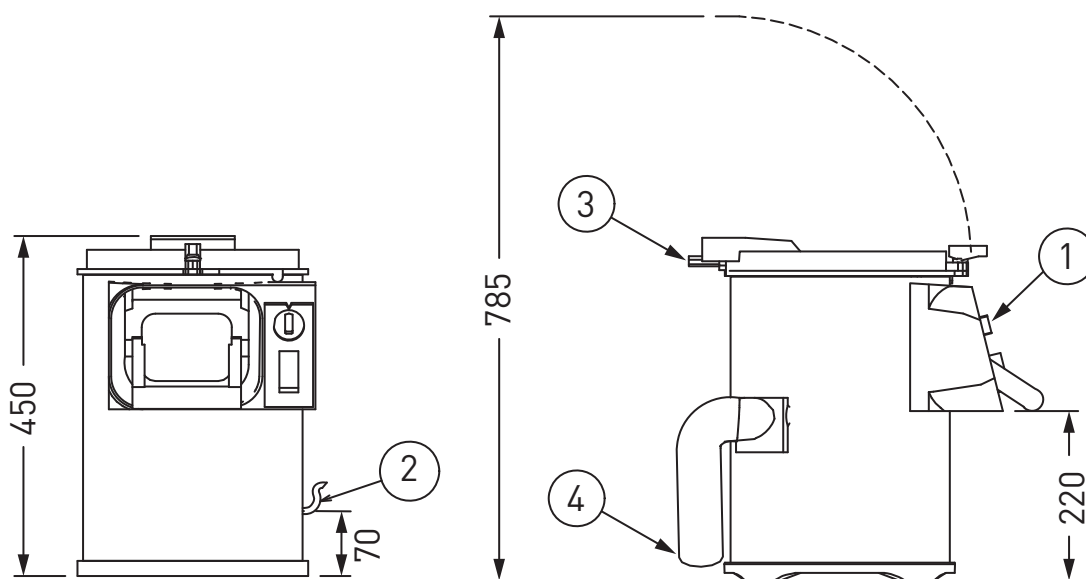

- 1. ON/OFF switch with timer.
- 2. Electrical connection.
- 3. Water connection 1/2".
- 4. Drain Ø 47 mm.
- 5. Drain Ø 50 mm with drain hose.
- 6. S/S filter table – optional extra.

TOP

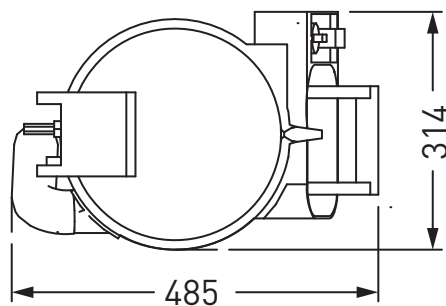

# DIMENSIONS

Model: T5S Rev. 1

SIDE

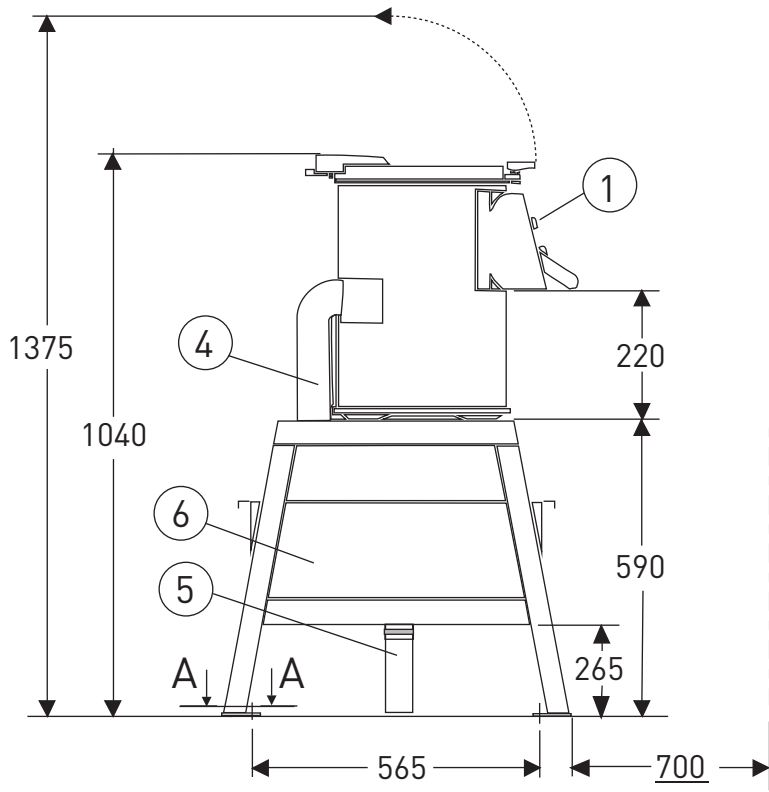

TOP

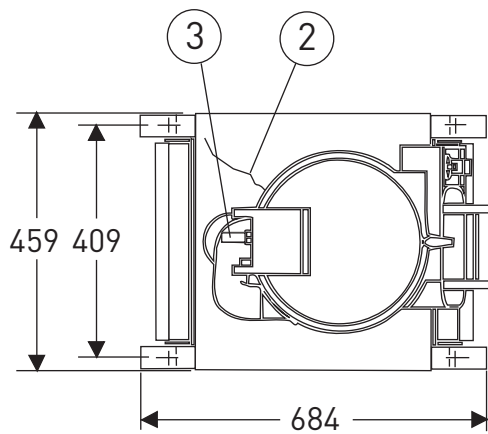

DETAIL OF FOOT S/S FILTER BASE

