



VEGETABLE PEELER, 15KG

Model: T15E-A

Article no: 601900

Power supply: 230V 1Ph ~50/60Hz

The peeling machine is to be used as equipment for vegetable preparation allowing to carry out different activities with the same tool like washing, scrubbing and peeling. It is made of stainless steel with a transparent removable lid in special high resistant plastic. The rotating plate is covered with a special abrasive lava stone material guaranteeing a high-quality finish to the peeled vegetables and a practically unlimited lifespan. When peeling is finished the products are channelled out through the hatch when manually activating the disc rotation.

An interlocking safety magnetic devices will stop the machine from operating when the lid or door is opened. Simple control panel with ON/OFF buttons and timer.

MAIN FEATURES

- Transparent lid
- Removable rotating plate
- Pulse function to control the unloading operation
- Timer with countdown display
- Magnetic safety system
- Suitable for 80-300 meals per service
- Complete stainless steel construction
- IP55 waterproof touch button control panel
- Transparent BPA free cover

T15E-A, 601900
17-01-24 (07:31)

Subject to change without notice
For correct installation, refer to the installation manual

TECHNICAL DATA

T15E-A, 601900, 17-01-24 (07:31)

Model Number Specific	T15E-A
Voltage (V)	230
Phase	1
Frequency (Hz)	50/60
Loading (kW)	0,37
IP Class	55
Capacity (kg)	15
Capacity, max (kg/h)	240
Width, net (mm)	440
Depth, net (mm)	690
Height, net (mm)	750
Weight, net (kg)	40
Weight, gross (kg)	52
Volume, net (m3)	0,34
Volume, gross (m3)	0,44
Connection Cable, length (m)	2
Plug type	Schuko
Cold water inlet, diameter (")	1/2
Meals per service (pcs)	300
Noise level <(dB)	72

INCLUDED IN DELIVERY

1pcs of Abrasive plate for T10 or T15 (653203)

Loipart AB (HQ), **Sweden**
Tel. +46 313 920 100, loipart@loipart.se

LMG Finland oy, **Finland**
+358 40 664 6680, lmg@lmg.fi



Loipart USA inc, **USA**
Tel. +1 954 530 5276, loipartusa@loipart.com

Loipart SEA Pte Ltd, **Singapore**
Tel. +65 674 99 100, contact@loipart.sg

Visit us at www.loipart.com

DIMENSIONS

Model: T15E with stand 653202 Rev. 4

FRONT

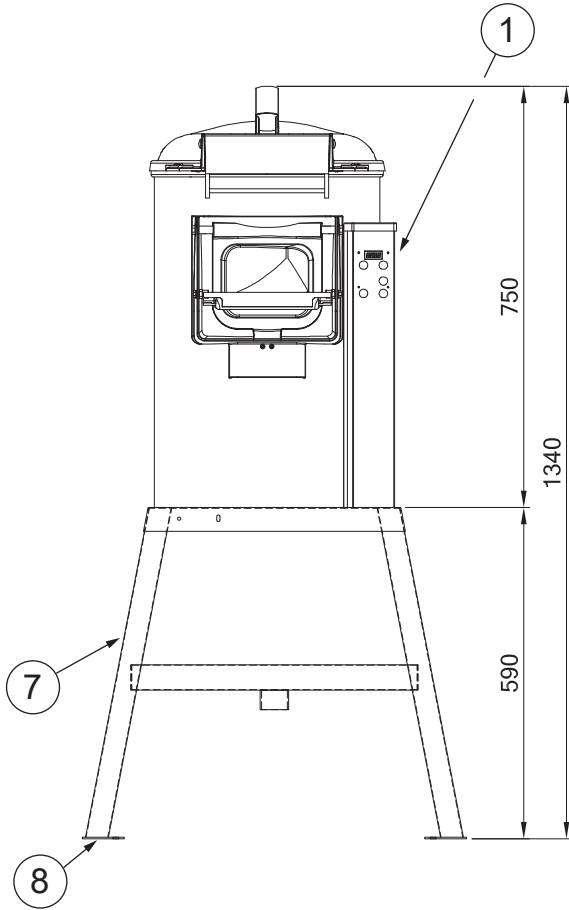

SIDE

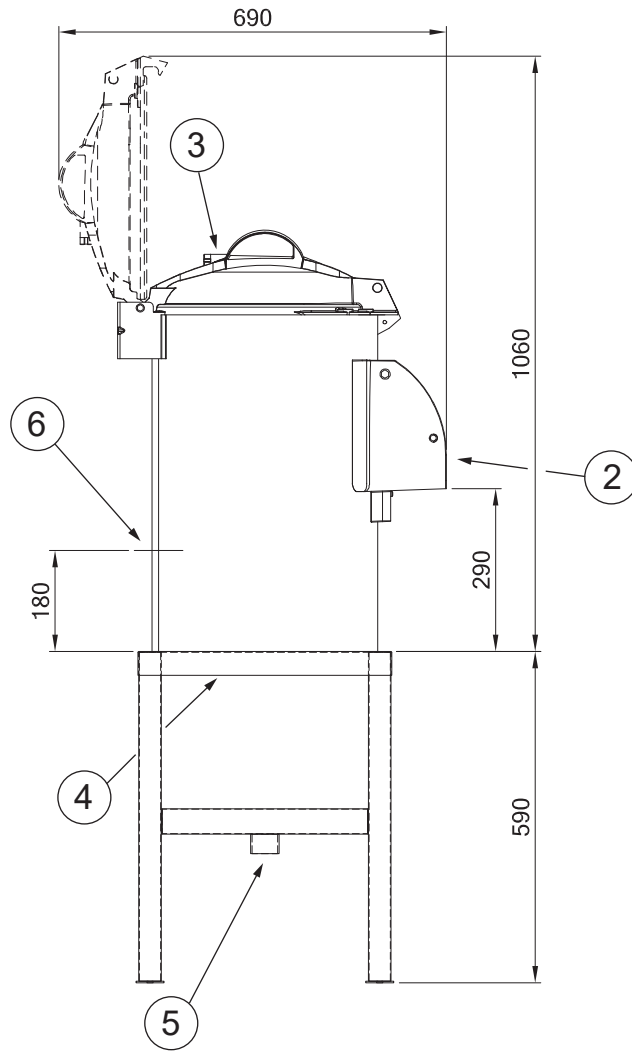

TOP

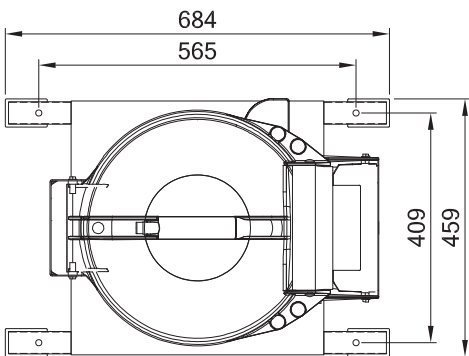

1. Control panel with reset button and timer
2. Outlet chute for vegetables
3. Water connection 1/2"
4. Drain Ø 80 mm
5. Drain Ø 50 mm, to be connected to floor drain or floor gully
6. Electrical connection
7. S/S filter table (optional extra)
8. Foot S/S filter table

DETAIL OF FOOT S/S FILTER TABLE

