



REFRIGERATOR 720 L, R290

Model: PS06R1FHC

Article no: 691349M

Power supply: 230V 1Ph ~50Hz

Full-door refrigerator in stainless steel with a large external panel and foot pedal. The model has CFC and HCFC free, ecological refrigerant type: R290.

The refrigerator's large digital display has a humidity selection button (3 preset levels), cabinet temperature display setting, and turbo frost cycle (to rapidly cool warm loads). In addition, the HACCP-compliant control with alarms and history of up to two months of events are kept in memory.

The structure of the wireframe condenser prevents dust and grease accumulation, thus avoiding periodical cleaning operations and reducing energy consumption.

A fully automatic Frost Watch Control will defrost when required and automatic evaporation of defrost water. The defrost starts only when ice builds up in the evaporator and adapts the defrosting duration to guarantee perfect ice removal and optimizing energy consumption.

The self-closing, on-site reversible door has a microswitch to switch off the fan when the door is opened. The optimized airflow within the chamber guarantees uniformity of temperature on all grids.

The refrigerator is prearranged to fit RS485 port to connect to a remote computer and integrated HACCP systems.

MAIN FEATURES

- Refrigerant gas R290 with the lowest environmental impact of all gases
- Operation temperature from 0°C to +10°C
- Suitable to contain 700x530 mm grids or shelves
- With high resistant foot pedal
- Self-closing and on-site reversible door
- Automatic evaporation of defrosting water
- Low noise level
- IPX5 frontal water protection
- 40°C maximum ambient temperature

PS06R1FHC, 691349M

05-02-24 (13:03)

TECHNICAL DATA

PS06R1FHC, 691349M, 05-02-24 (13:03)

Model Number Specific	PS06R1FHC
Voltage (V)	230
Phase	1
Frequency (Hz)	50
Loading (kW)	0,17
IP Class	X5
Width, net (mm)	900
Depth, net (mm)	700
Height, net (mm)	2075
Weight, net (kg)	140
Weight, gross (kg)	145
Volume, net (m3)	1,29
Volume, gross (m3)	1,67
Energy Class	B
Connection Cable, length (m)	3,5
Plug type	Schuko
Ambient temperature, max (°C)	40
Automatic defrost	Yes
Certifications	CE
Condensor type	Air cooled
Cooling fan	Yes
Door Hanging	Right
Door, type	Stainless steel
Doors, qty (pcs)	1
Exterior	Stainless steel
Filling factor refrigerant (g)	115
Grids, qty (pcs)	5
Installation, type	Floor model
Marine feet	Yes
Noise level <(dB)	52
Refrigerant type	R290
Temperature, max (°C)	10
Volume, refrigerator (L)	720

INCLUDED IN DELIVERY

5 pcs of plastic coated grid 700x530 (880343). 5 pairs of runners (880335). 1 of Pedal opening for cabinets (880324)

Loipart AB (HQ), Sweden
Tel. +46 313 920 100, loipart@loipart.se

LMG Finland oy, Finland
+358 40 664 6680, lmg@lmg.fi



Loipart USA inc, USA
Tel. +1 954 530 5276, loipartusa@loipart.com

Loipart SEA Pte Ltd, Singapore
Tel. +65 674 99 100, contact@loipart.sg

Visit us at www.loipart.com

DIMENSIONS

Model: PS06R1FHC Rev. 1

FRONT

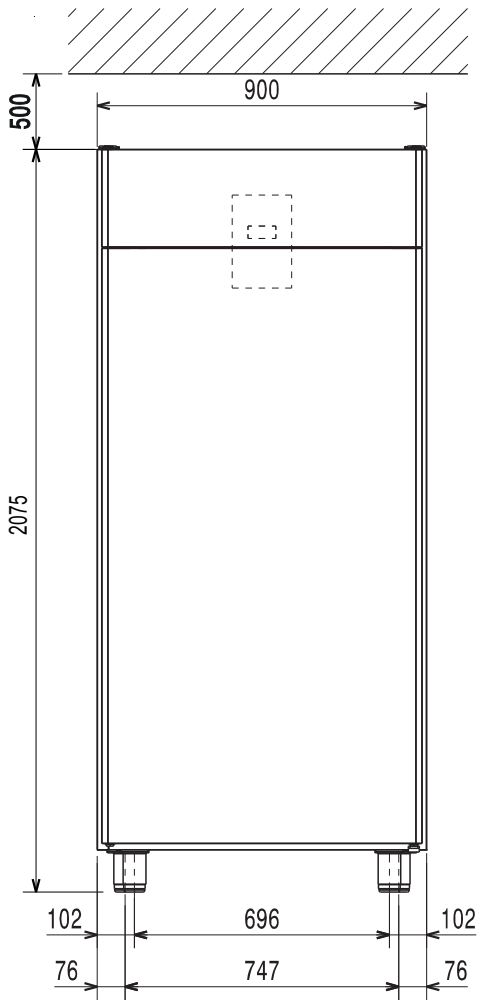

SIDE

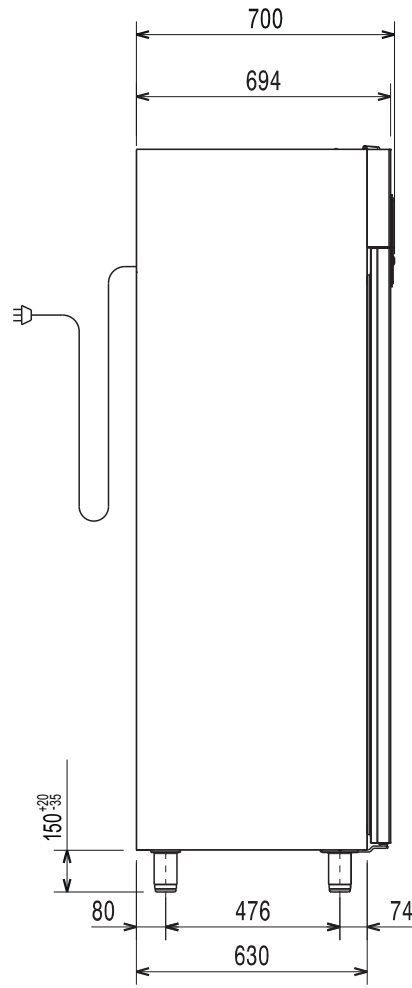

TOP

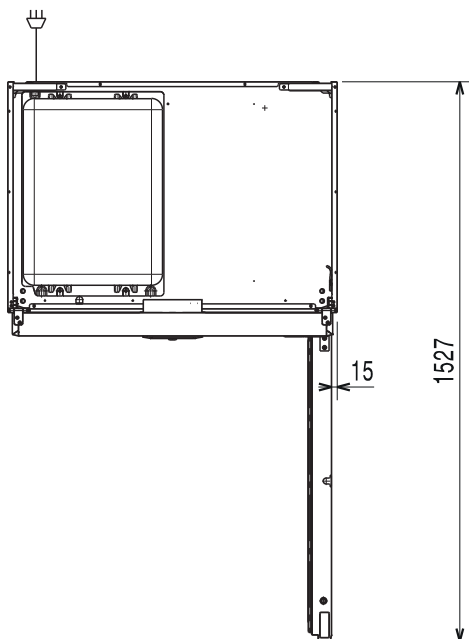

1. Electrical connection

DIMENSIONS

Model: PS06R1FHC Rev. 1

DETAIL MARINE FEET

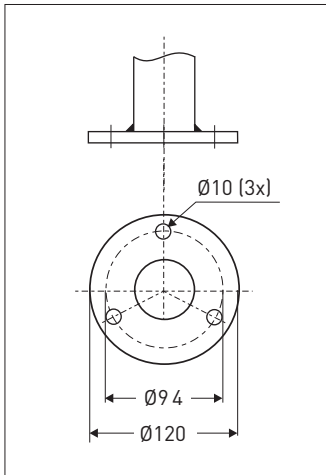

POSITIONING

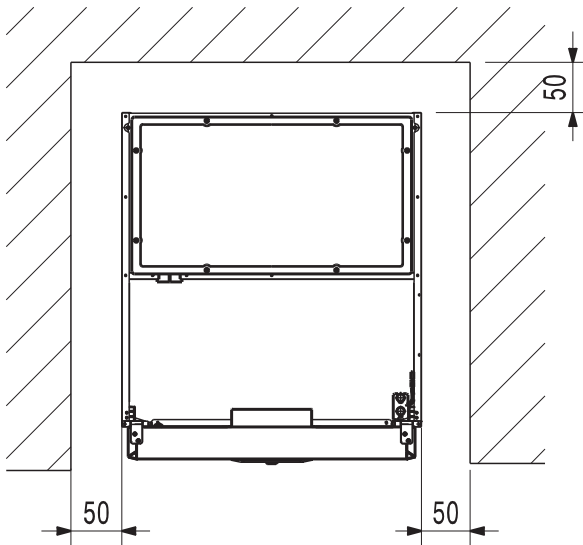

ENERGY LABEL

