



## REFRIGERATOR 2 DOORS 720 L, R290

Model: PS09R2FHC

Article no: 691351M

Power supply: 230V 1Ph ~50Hz

Two-door refrigerator in stainless steel with a large external panel and foot pedal. The model has CFC and HCFC free, ecological refrigerant type: R290.

The refrigerator's large digital display has a humidity selection button (3 preset levels), cabinet temperature display setting, and turbo frost cycle (to rapidly cool warm loads). In addition, the HACCP-compliant control with alarms and history of up to two months of events are kept in memory.

The structure of the wireframe condenser prevents dust and grease accumulation, thus avoiding periodical cleaning operations and reducing energy consumption.

A fully automatic Frost Watch Control will defrost when required and automatic evaporation of defrost water. The defrost starts only when ice builds up in the evaporator and adapts the defrosting duration to guarantee perfect ice removal and optimizing energy consumption.

The self-closing, on-site reversible door has a microswitch to switch off the fan when the door is opened. The optimized airflow within the chamber guarantees uniformity of temperature on all grids.

The refrigerator is prearranged to fit RS485 port to connect to a remote computer and integrated HACCP systems.

A foot pedal is available as an optional extra.

### MAIN FEATURES

- Refrigerant gas R290 with the lowest environmental impact of all gases
- Operation temperature from 0°C to +10°C
- Suitable to contain 520x442 mm grids or shelves
- Self-closing and on-site reversible door
- Automatic evaporation of defrosting water
- Low noise level
- IPX5 frontal water protection
- 40°C maximum ambient temperature

PS09R2FHC, 691351M

05-02-24 (13:04)

## TECHNICAL DATA

PS09R2FHC, 691351M, 05-02-24 (13:04)

|                                       |                 |
|---------------------------------------|-----------------|
| <b>Model Number Specific</b>          | PS09R2FHC       |
| <b>Voltage (V)</b>                    | 230             |
| <b>Phase</b>                          | 1               |
| <b>Frequency (Hz)</b>                 | 50              |
| <b>Loading (kW)</b>                   | 0,17            |
| <b>IP Class</b>                       | X5              |
| <b>Width, net (mm)</b>                | 900             |
| <b>Depth, net (mm)</b>                | 700             |
| <b>Height, net (mm)</b>               | 2075            |
| <b>Weight, net (kg)</b>               | 140             |
| <b>Weight, gross (kg)</b>             | 145             |
| <b>Volume, net (m3)</b>               | 1,29            |
| <b>Volume, gross (m3)</b>             | 1,67            |
| <b>Energy Class</b>                   | B               |
| <b>Connection Cable, length (m)</b>   | 3,5             |
| <b>Plug type</b>                      | Schuko          |
| <b>Ambient temperature, max (°C)</b>  | 40              |
| <b>Automatic defrost</b>              | Yes             |
| <b>Certifications</b>                 | CE              |
| <b>Condensor type</b>                 | Air cooled      |
| <b>Cooling fan</b>                    | Yes             |
| <b>Door Hanging</b>                   | Right           |
| <b>Door, type</b>                     | Stainless steel |
| <b>Doors, qty (pcs)</b>               | 2               |
| <b>Exterior</b>                       | Stainless steel |
| <b>Filling factor refrigerant (g)</b> | 115             |
| <b>Grids, qty (pcs)</b>               | 4               |
| <b>Installation, type</b>             | Floor model     |
| <b>Marine feet</b>                    | Yes             |
| <b>Noise level &lt;(dB)</b>           | 58              |
| <b>Refrigerant type</b>               | R290            |
| <b>Temperature, max (°C)</b>          | 10              |
| <b>Volume, refrigerator (L)</b>       | 720             |

## INCLUDED IN DELIVERY

4 pcs of Plastic coated grid (700x530). 4 of a Kit pair of runners.

Loipart AB (HQ), Sweden  
Tel. +46 313 920 100, loipart@loipart.se

LMG Finland oy, Finland  
+358 40 664 6680, lmg@lmg.fi



Loipart USA inc, USA  
Tel. +1 954 530 5276, loipartusa@loipart.com

Loipart SEA Pte Ltd, Singapore  
Tel. +65 674 99 100, contact@loipart.sg

Visit us at [www.loipart.com](http://www.loipart.com)

# DIMENSIONS

Model: PS09R2FHC Rev. 1

FRONT

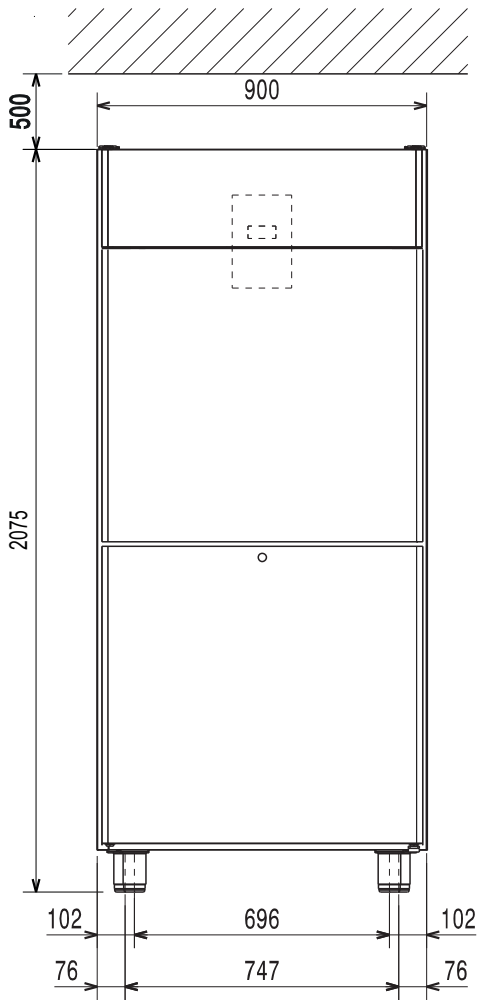

SIDE

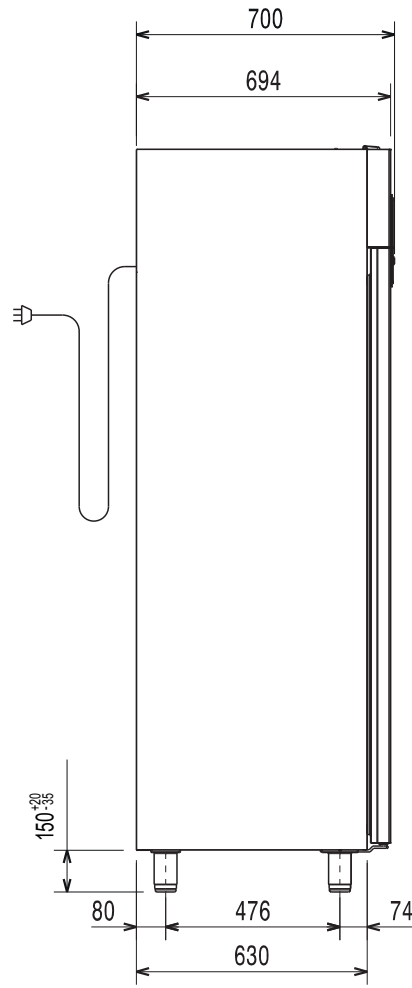

TOP

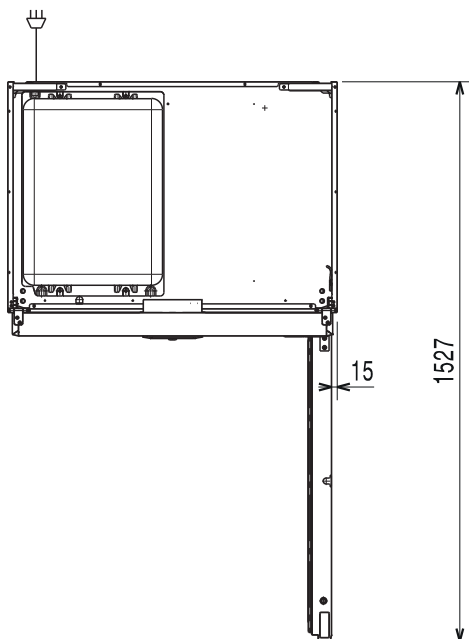

1. Electrical connection

# DIMENSIONS

Model: PS09R2FHC Rev. 1

## DETAIL MARINE FEET

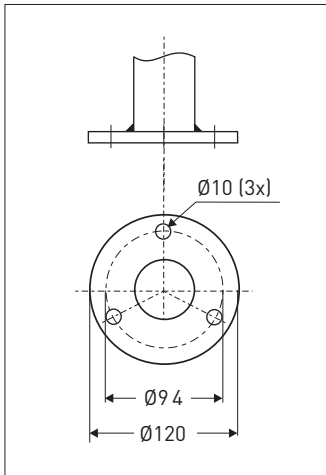

## POSITIONING

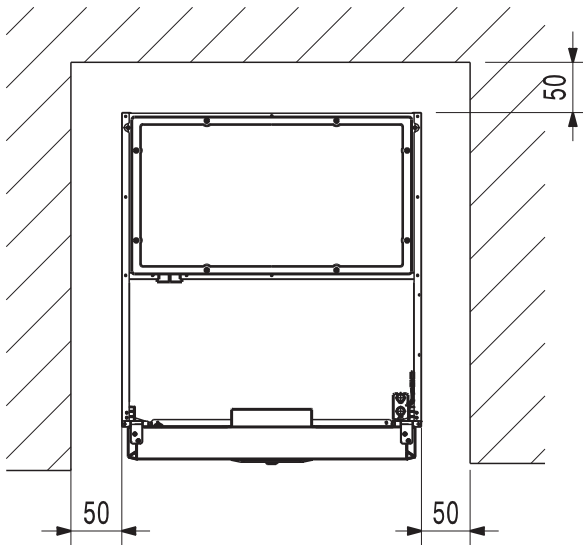

## ENERGY LABEL

