



RANGE 6 HOT PLATES

Model: FS6090M-4

Article no: FRB7022790002M

Power supply: 400V 3Ph ~50Hz

The range is made entirely in stainless steel with semi-polished Scotch Brite finish. It is equipped with 6 cooking plates made of cast iron controlled by 3-step switches. Control switches and pilot lamps indicating their actions are located on the front panel.

Hot plates are carefully mounted and balanced to form a completely flat hob surface. Large pots and pans can be placed over several hotplates at the same time providing full contact.

The range is provided with marine feet for bolting or welding to the deck. Installation and service are carried out at the front of the range.

MAIN FEATURES

- Stainless steel execution
- Hygienic design
- Powerful with high capacity
- Removable drip pan
- IP54 water protection class
- Easy to maintain

FS6090M-4, FRB7022790002M

08-09-22 (10:36)

TECHNICAL DATA

FS6090M-4, FRB7022790002M, 08-09-22 (10:36)

Model Number Specific	FS6090M-4
Voltage (V)	400
Phase	3
Frequency (Hz)	50
Loading (kW)	24
Fuse (A)	25
IP Class	54
Width, net (mm)	1110
Depth, net (mm)	770
Height, net (mm)	900
Weight, net (kg)	115
Weight, gross (kg)	130
Volume, net (m3)	0,77
Volume, gross (m3)	1
Plug type	None
Product brand	Loipart
Cast iron pan	Yes
Certifications	CE
Front rail, included	Yes
Hot plate, qty (pcs)	6
Hot plate, type	Square
Installation, type	Floor model
Marine feet	Yes
Other general information	4kW per plate.

INCLUDED IN DELIVERY

Rolling rack and front hand rail.

Loipart AB (HQ), **Sweden**
Tel. +46 313 920 100, loipart@loipart.se

LMG Finland oy, **Finland**
+358 40 664 6680, lmg@lmg.fi



Loipart USA inc, **USA**
Tel. +1 954 530 5276, loipartusa@loipart.com

Loipart SEA Pte Ltd, **Singapore**
Tel. +65 674 99 100, contact@loipart.sg

Visit us at www.loipart.com

FRONT

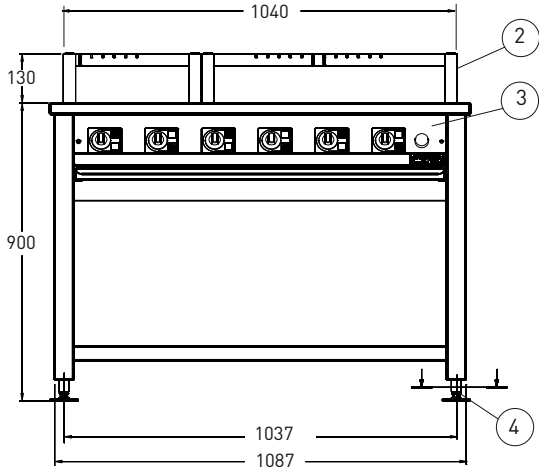

SIDE

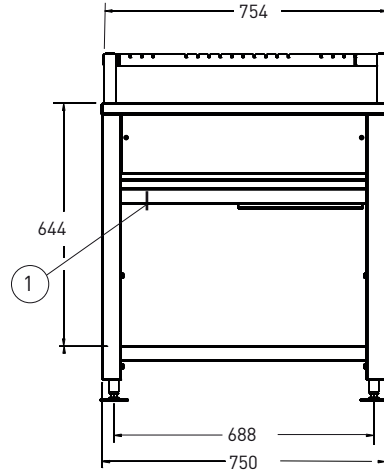

TOP

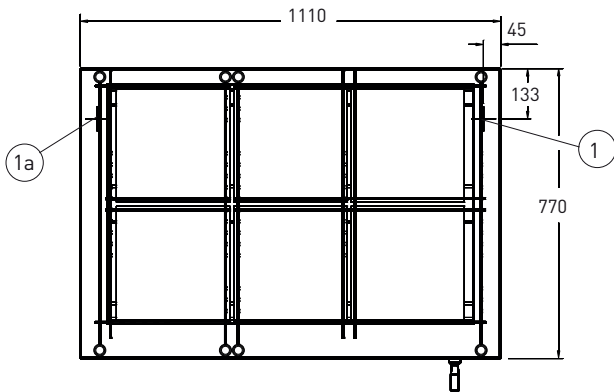

- 1 Electrical connection
- 1a. Alternative electrical connection
- 2. Rolling rack, optional extra
- 3. Control panel
- 4. Marine legs

DETAIL MARINE FEET
Section A-A

