



RANGE, 4 HOT PLATES AND HEIGHT ADJUSTABLE

Model: FSH4090M-2-5

Article no: L12010

Power supply: 440V 3Ph ~60Hz

The hydraulically adjustable range is made entirely in stainless steel with semi-polished Scotch Brite finish. It is equipped with 4 cooking plates made of cast iron controlled by 3-step switches. Control switches and pilot lamps indicating their actions are located on the front panel. Hot plates are carefully mounted and balanced to form a completely flat hob surface. Large pots and pans can be placed over several hotplates at the same time providing full contact.

The range is provided with hydraulically adjustable telescopic legs making it possible to adjust the height between 756-968 mm. The legs are equipped with marine feet for bolting or welding to the deck.

Installation and service are carried out at the front of the range.

MAIN FEATURES

- Stainless steel execution
- Hygienic design
- Hydraulically adjustable height
- Powerful with high capacity
- Removable drip pan
- IP54 water protection class
- Easy to maintain

FSH4090M-2-5, L12010

08-09-22 (10:32)

Subject to change without notice
For correct installation, refer to the installation manual

TECHNICAL DATA

FSH4090M-2-5, L12010, 08-09-22 (10:32)

Model Number Specific	FSH4090M-2-5
Voltage (V)	440
Phase	3
Frequency (Hz)	60
Loading (kW)	10
Fuse (A)	20
IP Class	54
Width, net (mm)	800
Depth, net (mm)	770
Height, net (mm)	1000
Weight, net (kg)	90
Weight, gross (kg)	105
Volume, net (m3)	0,62
Volume, gross (m3)	0,8
Plug type	None
Product brand	Loipart
Adjustable height	Yes
Adjustable height	Yes
Cast iron pan	Yes
Certifications	CE
Front rail, included	Yes
Hot plate, qty (pcs)	4
Hot plate, type	Square
Installation, type	Floor model
Marine feet	Yes

INCLUDED IN DELIVERY

Rolling rack and front hand rail.

Loipart AB (HQ), **Sweden**
Tel. +46 313 920 100, loipart@loipart.se

LMG Finland oy, **Finland**
+358 40 664 6680, lmg@lmg.fi



Loipart USA inc, **USA**
Tel. +1 954 530 5276, loipartusa@loipart.com

Loipart SEA Pte Ltd, **Singapore**
Tel. +65 674 99 100, contact@loipart.sg

Visit us at www.loipart.com

FRONT

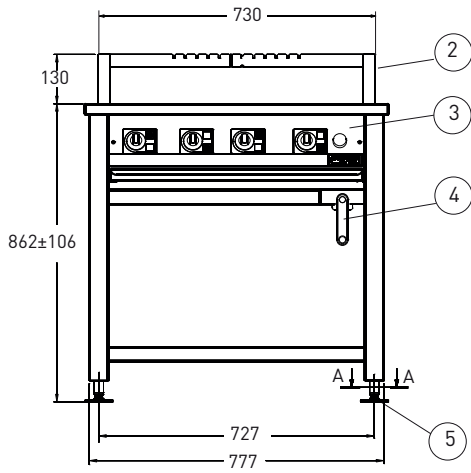

SIDE

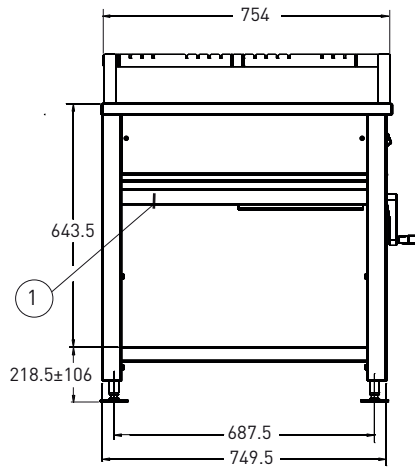

TOP

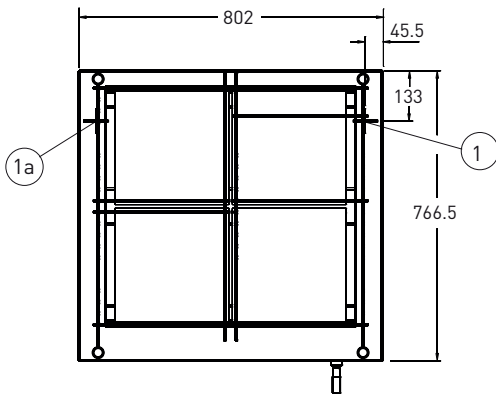

- 1 Electrical connection
- 1a. Alternative electrical connection
- 2. Rolling rack, optional extra
- 3. Control panel
- 4. Handle for height adjustment
- 5. Marine legs

DETAIL MARINE FEET

Section A-A

