



PLANETARY MIXER 30L WITH HUB

Model: LMX30-JT302H

Article no: JT305H440603

Power supply: 440V 3Ph ~60Hz

This planetary mixer has a cast iron body and a powerful custom built motor with three fixed speeds. It's belt driven with gear box and high torque transmission. Heat-treated hardened steel alloy gears and shafts and permanently lubricated transmission.

The mixer is operated in front and has a 15 minute interval timer and a thermal overload protection. The mixer is equipped with a stainless steel bowl guard and lift. It also has a built in ingredient chute for adding ingredients while the mixer is running. With the attachment hub (#12) it's possible to make the mixer with the attachments (optional extras) as meat mincer and vegetable preparation.

MAIN FEATURES

- Three fixed speeds and timer.
- Overload protection.
- Bowl detection device.
- Ingredient chute.
- Attachment hub #12.
- Supplied with spiral hook, paddle and whisk.

LMX30-JT302H, JT305H440603

15-01-24 (16:19)

TECHNICAL DATA

LMX30-JT302H, JT305H440603, 15-01-24 (16:19)

Model Number Specific	LMX30-JT302H
Voltage (V)	440
Phase	3
Frequency (Hz)	60
Loading (kW)	0,75
Max Amps in Phase (A)	1,7
IP Class	23
Capacity (L)	30
Width, net (mm)	707
Depth, net (mm)	675
Height, net (mm)	1164
Weight, net (kg)	96
Weight, gross (kg)	141
Volume, net (m3)	0,79
Volume, gross (m3)	1,03
Connection Cable, length (m)	0
Plug type	None
Attachment drive	Yes
Installation, type	Floor model
Mixer, type	Planetary
Noise level <(dB)	64,4

INCLUDED IN DELIVERY

A 30 liter stainless steel bowl, flat beater (aluminum), stainless steel wire whip & spiral dough hook (aluminum)

Loipart AB (HQ), **Sweden**
Tel. +46 313 920 100, loipart@loipart.se

LMG Finland oy, **Finland**
+358 40 664 6680, lmg@lmg.fi



Loipart USA inc, **USA**
Tel. +1 954 530 5276, loipartusa@loipart.com

Loipart SEA Pte Ltd, **Singapore**
Tel. +65 674 99 100, contact@loipart.sg

Visit us at www.loipart.com

DIMENSIONS

Model: LMX30 Rev. 1

FRONT

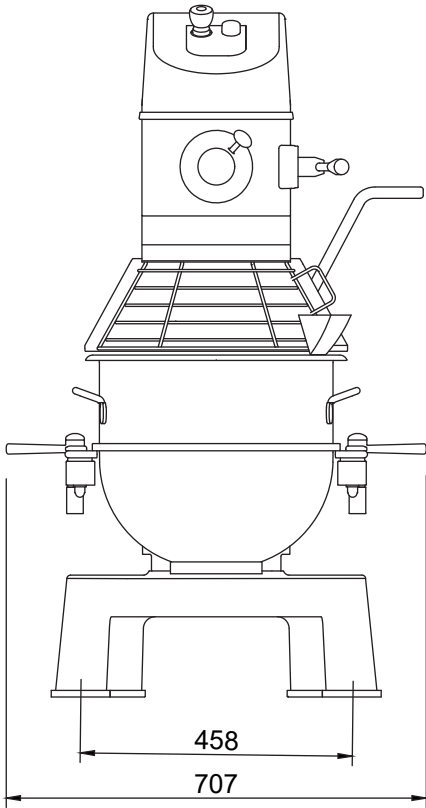

SIDE

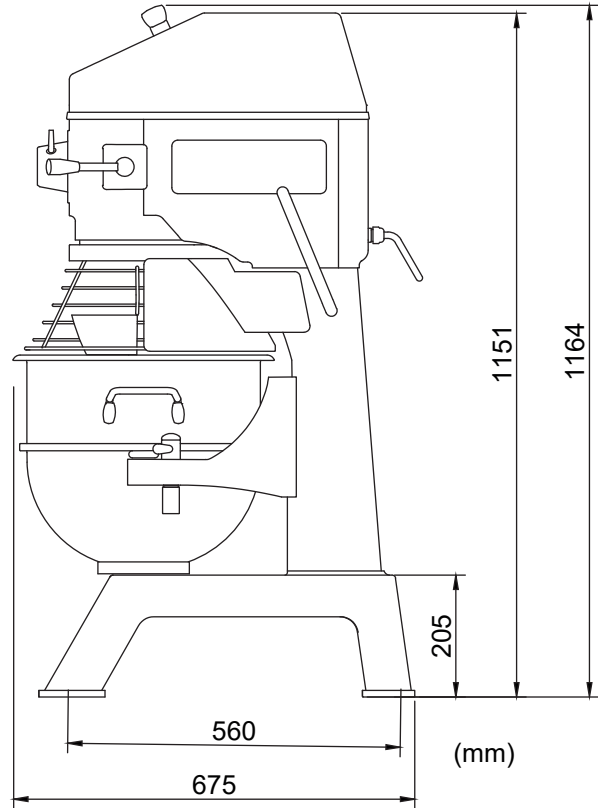

DETAIL MARINE FEET

