



PLANETARY MIXER 20L WITH HUB

Model: XBM20AB36

Article no: 600252

Power supply: 440V 3Ph ~60Hz

Floor model, suitable for all kneading, blending and whipping operations. Body in non-corrosive material with 20 litre 18/8 (AISI 302) stainless steel bowl. Asynchronous motor with high start-up torque. (750 W) with mechanical speed variator (8 speed levels from 35 to 180 rpm) The bowl detection device allows the mixer to switch on only when the bowl and the safety screen are properly installed and positioned together. Raising and lowering of the bowl controlled by lever with an automatic locking of the bowl when in the raised position. The solid BPA-free safety screen and stainless steel wire structure are both removable and demountable and dishwasher safe for an easy cleaning. They are also fitted with a removable chute to for the possibility to add products while working, thus ensuring operator safety. The flat touch button control panel is water proof (IP55) and equipped with a timer from 0-59 min. Equipped with accessory drive hub type H.

MAIN FEATURES

- Maximum capacity 6 kg (cold water paste with 60% hydration).
- Suitable for 50-150 meals per service.
- Pivoting and removable BPA-free wire safetyscreen.
- Waterproof touch button control panel.
- Bowl detection device.
- Planetary movement based on self lubricatinggears, eliminating any risk of leaks.
- Adjustable feet to perfect stability.
- Supplied with spiral hook, paddle and whisk.

XBM20AB36, 600252

15-01-24 (14:29)

TECHNICAL DATA

XBM20AB36, 600252, 15-01-24 (14:29)

| | |
|-------------------------------------|-------------|
| Model Number Specific | XBM20AB36 |
| Voltage (V) | 440 |
| Phase | 3 |
| Frequency (Hz) | 60 |
| Loading (kW) | 0,75 |
| Fuse (A) | 10 |
| IP Class | 23 |
| Capacity (L) | 20 |
| Capacity (kg) | 6 |
| Width, net (mm) | 521 |
| Depth, net (mm) | 685 |
| Height, net (mm) | 1230 |
| Weight, net (kg) | 95 |
| Weight, gross (kg) | 114 |
| Volume, net (m3) | 0,36 |
| Volume, gross (m3) | 0,72 |
| Connection Cable, length (m) | 0 |
| Attachment drive | Yes |
| Installation, type | Floor model |
| Mixer, type | Planetary |
| Noise level <(dB) | 70 |

INCLUDED IN DELIVERY

Spiral hook, wire whisk, paddle (and mixing bowl 20 L).

Loipart AB (HQ), **Sweden**
Tel. +46 313 920 100, loipart@loipart.se

LMG Finland oy, **Finland**
+358 40 664 6680, lmg@lmg.fi



Loipart USA inc, **USA**
Tel. +1 954 530 5276, loipartusa@loipart.com

Loipart SEA Pte Ltd, **Singapore**
Tel. +65 674 99 100, contact@loipart.sg

Visit us at www.loipart.com

DIMENSIONS

Model: XBM20A Rev. 2

SIDE

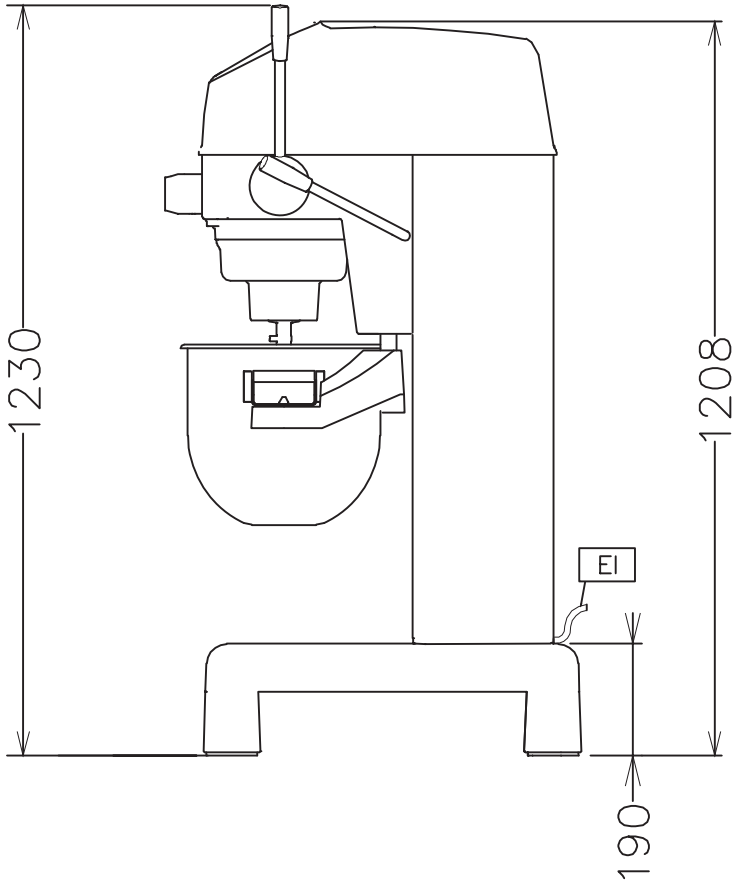

FRONT

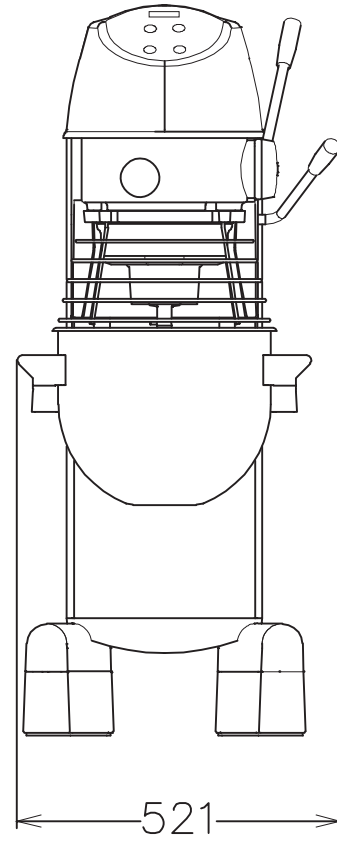

TOP

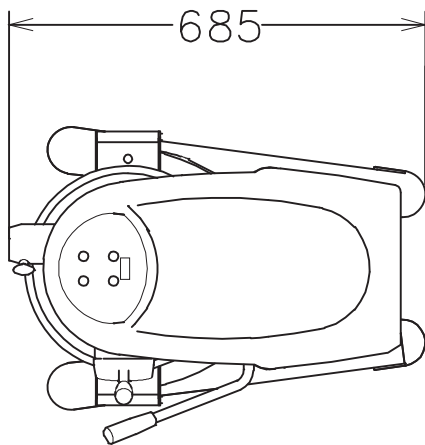

POSITION OF FEET

