



MEAT MINCER 80 KG/H

Model: TS8E

Article no: L15010

Power supply: 230V 1Ph ~50Hz

The professional TS 8E meat mincer is best used in galleys. The running reverse and the easy disassembly of the cutting unit make its use really simple and simplify cleaning. The meat mincer is manufactured with anodized aluminium housing, cutting group and stainless steel funnel. The compact size and low weight in combination with single phase electric connection means easy handling and installation. The high powerful motor permits to mince till 80 kg/hour and has an overload switch. As standard the mincer is equipped with a short cutting group including one knife and one disc with hole diameter 4.5 mm. The mincers and its fittings are built according to the CE rules in the field of hygiene and of safety and according to the specific rules concerning the mincers. Electrical protection class is IP55. For further specifications, please see overleaf.

MAIN FEATURES

- Anodized Aluminium/Stainless Steel
- Easy to Disassemble
- Reverse Gear Feature
- Single Phase Electric Connection
- Easy to Clean

TS8E, L15010
17-01-24 (07:27)

TECHNICAL DATA

TS8E, L15010, 17-01-24 (07:27)

Model Number Specific	TS8E
Voltage (V)	230
Phase	1
Frequency (Hz)	50
Loading (kW)	0,5
IP Class	55
Capacity (kg/h)	80
Width, net (mm)	170
Depth, net (mm)	350
Height, net (mm)	380
Weight, net (kg)	13
Weight, gross (kg)	15
Volume, net (m3)	0,02
Volume, gross (m3)	0,03
Noise level <(dB)	70

Loipart AB (HQ), **Sweden**
Tel. +46 313 920 100, loipart@loipart.se

LMG Finland oy, **Finland**
+358 40 664 6680, lmg@lmg.fi



Loipart USA inc, **USA**
Tel. +1 954 530 5276, loipartusa@loipart.com

Loipart SEA Pte Ltd, **Singapore**
Tel. +65 674 99 100, contact@loipart.sg

Visit us at www.loipart.com

DIMENSIONS

Model: 513025 Rev. 1

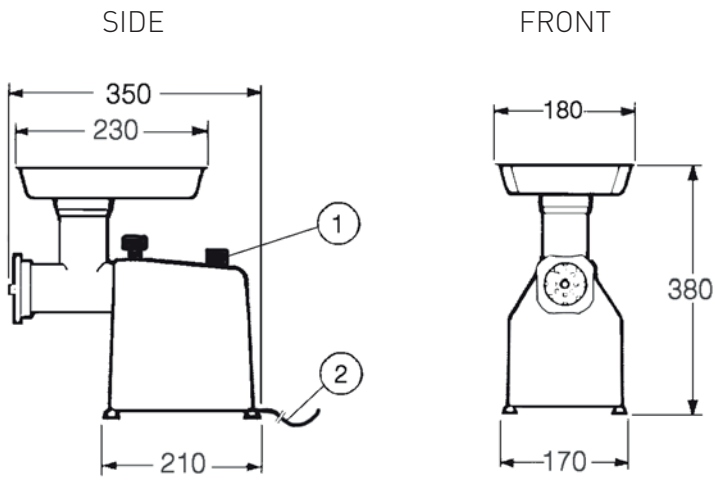

- 1. Reversible start switch
- 2. Electrical cord with plug