



MEAT BAND SAW, TABLE TYPE

Model: Velox1830

Article no: L22037

Power supply: 230V 1Ph ~50Hz

VELOX 1830 is a bench-banded bone saw in an anodized aluminum casting body that ensures linear blade rotation without flexions. The working surface and portioner are made in stainless steel.

The saw is equipped with a blade tensioner, blade scraper, and blade guide. A safety microswitch is located on the casing door.

The model complies with European safety rules and is CE marked.

MAIN FEATURES

- Blade size is 1830 mm.
- Cutting capacity is 210x270mm

Velox1830, L22037
17-01-24 (07:27)

Subject to change without notice
For correct installation, refer to the installation manual

TECHNICAL DATA

Velox1830, L22037, 17-01-24 (07:27)

Model Number Specific	Velox1830
Voltage (V)	230
Phase	1
Frequency (Hz)	50
Loading (kW)	1,5
Fuse (A)	16
IP Class	54
Width, net (mm)	525
Depth, net (mm)	445
Height, net (mm)	870
Weight, net (kg)	40
Weight, gross (kg)	45

Loipart AB (HQ), **Sweden**
Tel. +46 313 920 100, loipart@loipart.se

LMG Finland oy, **Finland**
+358 40 664 6680, lmg@lmg.fi



Loipart USA inc, **USA**
Tel. +1 954 530 5276, loipartusa@loipart.com

Loipart SEA Pte Ltd, **Singapore**
Tel. +65 674 99 100, contact@loipart.sg

Visit us at www.loipart.com

DIMENSIONS

Model: Velox1830 Rev. 1

FRONT

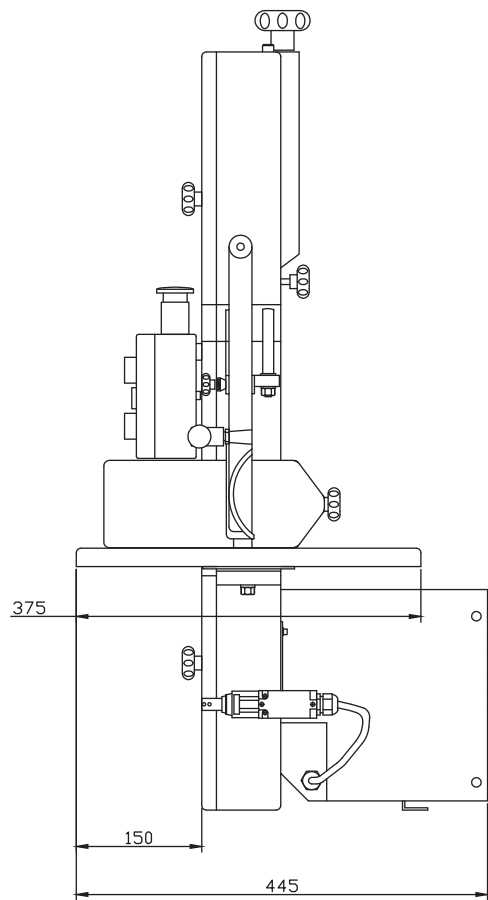

SIDE

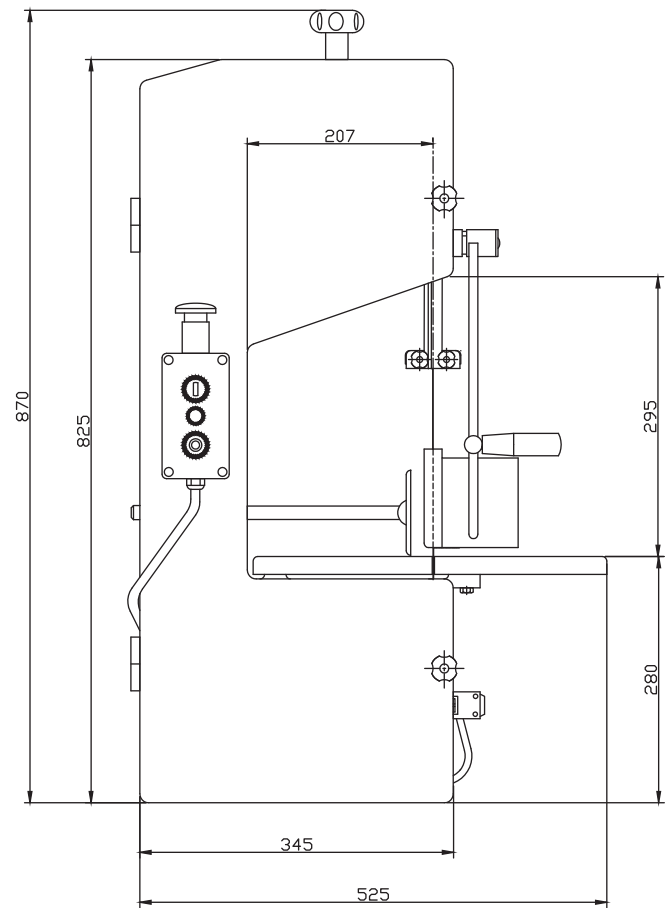

POSITION OF FEET

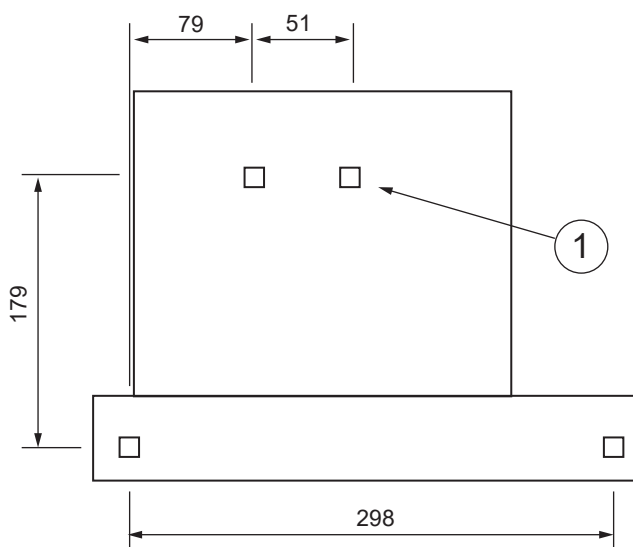

TOP

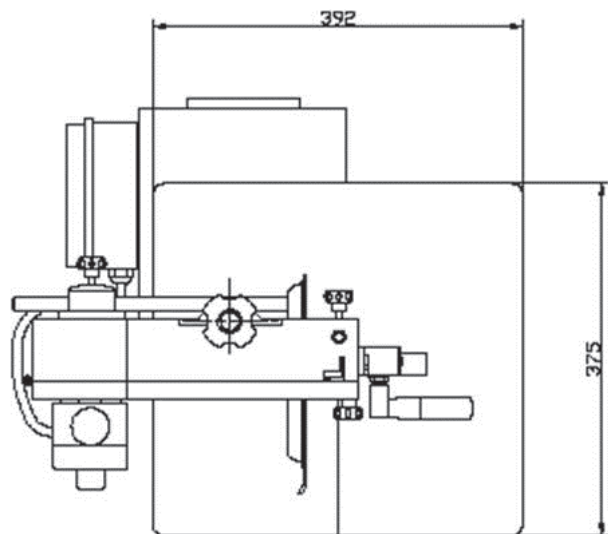

1. 4x12MA threaded holes