



DEEP FAT FRYER 2X9-10 L

Model: EVO-2525

Article no: 8430M

Power supply: 400V 3Ph ~50/60Hz

The fryer is made entirely in stainless steel with a strong, 1.5 mm thick, seamless pressed stainless steel oil tank. It is tested to satisfy the heavy use and demanding safety standards required at sea.

The fryer is provided with a security system that deactivates the unit when opening the tap and washing the heating element. The rounded edges, corners, and the hinged construction of the stainless steel heating elements facilitate cleaning. The drain with a cold zone for waste recovery is located in the cabinet and provided with a ball-type drain valve with a security lock.

The thermostat probe is fixed to the heating element, which means quick response and precise temperature control. Using a "standby mode" reduces oil temperature, automatically saving both oil and electricity.

According to Solas rules, the connection points can be used directly in the unit or use the separate 4-wire Solas security cord delivered with the machine.

An automatic basket lift and a recycling pump with a micro-filter are available as optional extras.

MAIN FEATURES

- High Output
- Excellent Frying Results
- Energy And Oil Saving
- Insulated Execution
- Precise Temperature Control
- Easy To Clean
- Protection Class IP X5
- Manufactured Acc. To Solas Recommendations

EVO-2525, 8430M

07-10-22 (12:09)

TECHNICAL DATA

EVO-2525, 8430M, 07-10-22 (12:09)

Model Number Specific	EVO-2525
Voltage (V)	400
Phase	3
Frequency (Hz)	50/60
Loading (kW)	14,4
Max Amps in Phase (A)	20
Capacity (L)	20
Width, net (mm)	496
Depth, net (mm)	600
Height, net (mm)	900
Weight, net (kg)	59
Weight, gross (kg)	68
Volume, net (m3)	0,27
Volume, gross (m3)	0,35
Connection Cable, lenght (m)	2
Plug type	None
Product brand	Valentine
Frying capacity, chips (kg/h)	50
Installation, type	Floor model
Marine feet	Yes
Noise level <(dB)	70
SOLAS approved	Yes

INCLUDED IN DELIVERY

Lid, frying basket and oil bucket with filter.

Loipart AB (HQ), **Sweden**
Tel. +46 313 920 100, loipart@loipart.se

LMG Finland oy, **Finland**
+358 40 664 6680, lmg@lmg.fi



Loipart USA inc, **USA**
Tel. +1 954 530 5276, loipartusa@loipart.com

Loipart SEA Pte Ltd, **Singapore**
Tel. +65 674 99 100, contact@loipart.sg

Visit us at www.loipart.com

DIMENSIONS

Model: EVO-2525 Rev. 1

FRONT

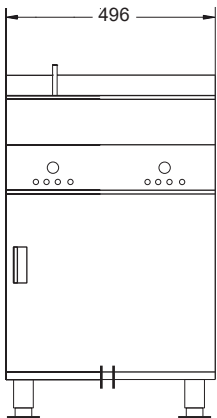

SIDE

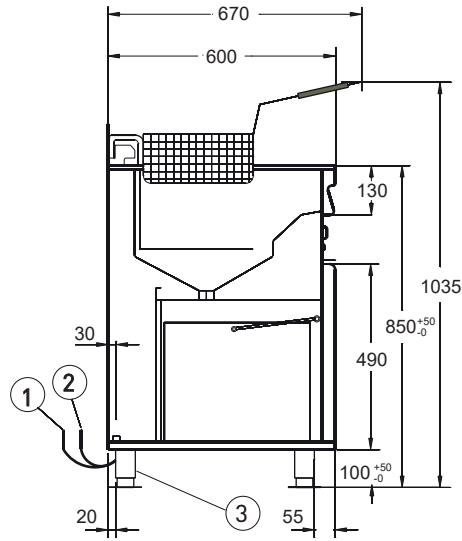

TOP

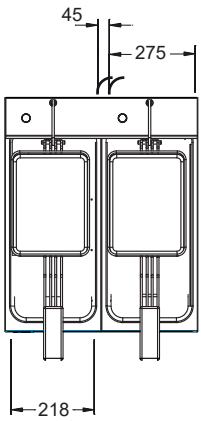

- 1. Electrical connection
- 2. Solas security connection
- 3. Marine foot

BOTTOM

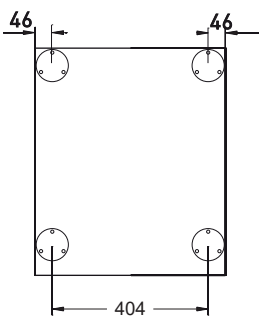

BASKET

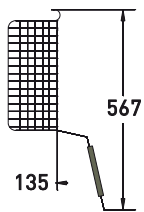

DETAIL MARINE FEET

adjustable in 50 mm steps:

