



DEEP FAT FRYER 14 L

Model: E7FRMD1FF6

Article no: 371163

Power supply: 440V 3Ph ~50/60Hz

The XP 700 range is designed to guarantee the highest level of performance, reliability, energy saving, safety standards and ergonomic operation.

The freestanding electric fryer is ideal for kitchens needing a versatile, efficient and easy to clean unit capable of cooking numerous portions time after time.

The fryer has high efficiency liftable incoloy armoured heating elements placed inside the deep drawn well.

Well with rounded corners for ease of cleaning. Right-angled side edges to allow flush-fitting joints between units, eliminating gaps and possible dirt traps. One piece pressed 1.5 mm worktop in Stainless steel. All exterior panels in Stainless Steel with Scotch Brite finishing.

The oil drains through a tap into a drainage container positioned under the well and all major compartments located in front of unit for ease of maintenance. Optional portable oil quality monitoring tool (code 9B8081) for efficient oil management.

MAIN FEATURES

- IPX 4 water protection.
- Overheat protection thermostat
- Thermostatic regulation of oil temperature up to a maximum of 185 °C
- Liftable incoloy armoured heating elements

E7FRMD1FF6, 371163

07-10-22 (12:03)

Subject to change without notice
For correct installation, refer to the installation manual

TECHNICAL DATA

E7FRMD1FF6, 371163, 07-10-22 (12:03)

Model Number Specific	E7FRMD1FF6
Voltage (V)	440
Phase	3
Frequency (Hz)	50/60
Loading (kW)	8,7
Max Amps in Phase (A)	11,2
IP Class	X4
Capacity (L)	14
Width, net (mm)	400
Depth, net (mm)	730
Height, net (mm)	850
Weight, net (kg)	47
Weight, gross (kg)	55
Volume, net (m3)	0,47
Volume, gross (m3)	0,61
Product brand	Electrolux Professional
Adjustable height	No
Baskets, qty (pcs)	1
Front rail, included	No
Fryer, type	Internal element
Installation, type	Floor model
Marine feet	Yes
Oil temperature (°C)	185
SOLAS approved	Yes
Timer	No
Touch control	No

INCLUDED IN DELIVERY

- 1 of Door for open base cupboard PNC 206350 • 1 of Full-size basket for 14 and 15lt free standing fryers PNC 921691 • 1 of Lid

Loipart AB (HQ), **Sweden**
Tel. +46 313 920 100, loipart@loipart.se

LMG Finland oy, **Finland**
+358 40 664 6680, lmg@lmg.fi



Loipart USA inc, **USA**
Tel. +1 954 530 5276, loipartusa@loipart.com

Loipart SEA Pte Ltd, **Singapore**
Tel. +65 674 99 100, contact@loipart.sg

Visit us at www.loipart.com

DIMENSIONS

Model: E7FRMD1FF Rev. 1

FRONT

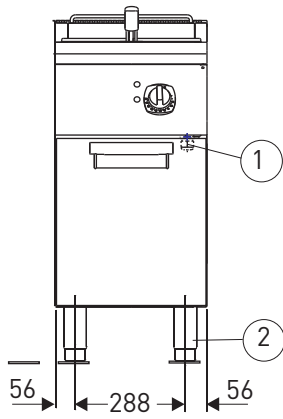

SIDE

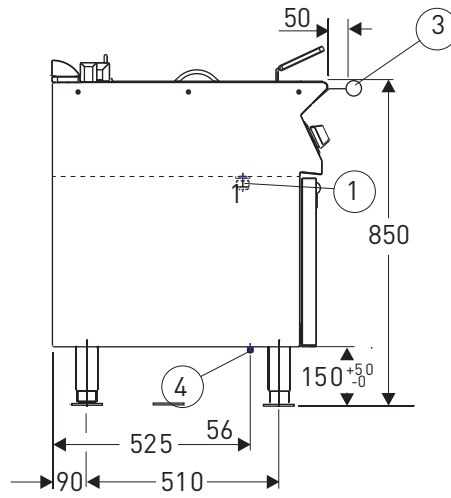

TOP

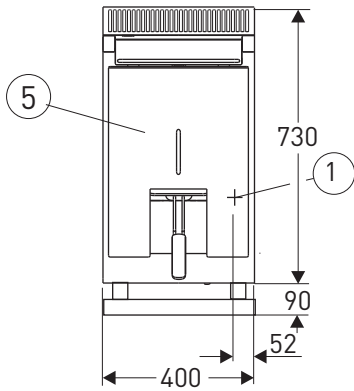

- 1. Electrical connection
- 2. Marine legs
- 3. Front hand rail (optional)
- 4. Equipotential screw
- 5. Lid (included in delivery)

DETAIL MARINE FEET

