



COMBI OVEN ICOMBI CLASSIC 10 GN 2/1

Model: iCombi Classic 102

Article no: L20080

Power supply: 400V 3Ph ~50/60Hz

The iCombi Classic works at a consistently high level, thanks to the central measurement and regulatory system for a uniform, individual cooking cabinet climate; the powerful fresh steam generator for optimal steam saturation; the high-performance dehumidification; increased quantity of fan wheels and optimal cooking cabinet design. This combined means energy is transferred to the food with precision and, where appropriate, with a lot of power. The result: large load size with excellent uniform results across all the racks. With up to 10% less energy and water consumption. For the one objective: producing consistently high quality results with crisp crusts, attractive diamond grill patterns, crispy breaded products.

The iCombi Classic features an effective steam generator for optimal steam performance even at low temperatures below 100 °C. Individual programming of up to 100 single or multi-level cooking programmes with up to 12 increments. Integrated, maintenance-free grease separation system with no additional grease filter

Care system: Automatic cleaning and descaling of steam generator. 4 different cleaning programmes for unsupervised cleaning, even overnight.

MAIN FEATURES

- Effective steam generator
- Colour display and soft keys
- Easy to use
- Effective cleaning
- Ergonomic door handle
- Adjustable door stopper

iCombi Classic 102, L20080
22-01-24 (14:14)

TECHNICAL DATA

iCombi Classic 102, L20080, 22-01-24 (14:14)

Model Number Specific	iCombi Classic 102
Voltage (V)	400
Phase	3
Frequency (Hz)	50/60
Loading (kW)	37,4
Max Amps in Phase (A)	54
Fuse (A)	63
IP Class	X5
Capacity, pans (pcs)	10
Width, net (mm)	1072
Depth, net (mm)	975
Height, net (mm)	1014
Weight, net (kg)	179
Weight, gross (kg)	206
Volume, net (m3)	1,06
Volume, gross (m3)	1,38
Connection Cable, length (m)	0
Plug type	None
Adapted for container sizes	GN
Automatic cleaning system	Yes
Certifications	CE
Chlorides (mg/l)	80
Cold water inlet, diameter (")	3/4
Drain pipe, diameter (mm)	50
Hardness, min (dH°)	5
Installation, type	Floor model
Marine feet	No
Noise level <(dB)	56
Oven, type	Combi
Pan sizes	GN2/1
Pressure (Bar)	3
Temperature, max (°C)	300
Touch control	No
USPH	Yes

Loipart AB (HQ), Sweden
Tel. +46 313 920 100, loipart@loipart.se

LMG Finland oy, Finland
+358 40 664 6680, lmg@lmg.fi



Loipart USA inc, USA
Tel. +1 954 530 5276, loipartusa@loipart.com

Loipart SEA Pte Ltd, Singapore
Tel. +65 674 99 100, contact@loipart.sg

Visit us at www.loipart.com

Water pressure, max (Bar)	6
Water pressure, min (Bar)	1

Loipart AB (HQ), **Sweden**
Tel. +46 313 920 100, loipart@loipart.se

LMG Finland oy, **Finland**
+358 40 664 6680, lmg@lmg.fi



Loipart USA inc. **USA**
Tel. +1 954 530 5276, loipartusa@loipart.com

Loipart SEA Pte Ltd, **Singapore**
Tel. +65 674 99 100, contact@loipart.sg

Visit us at www.loipart.com

DIMENSIONS

Model: iCombi Pro 102 Rev. 2

FRONT

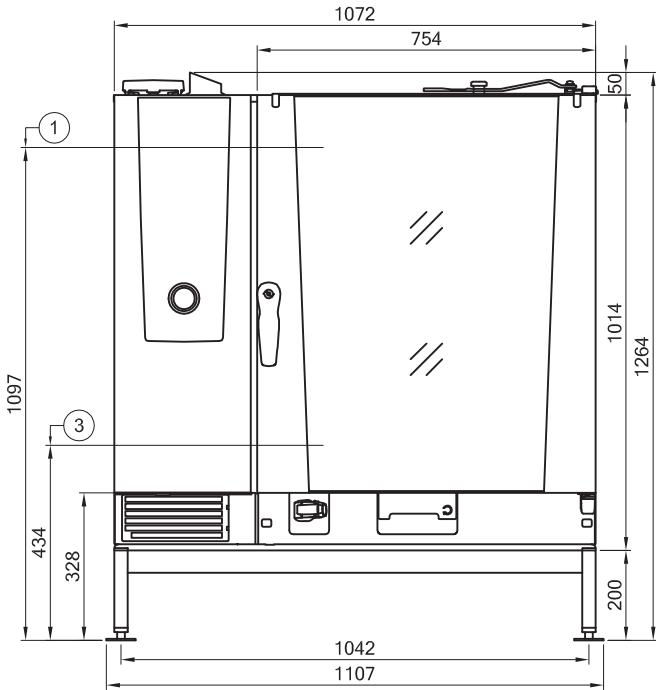

SIDE

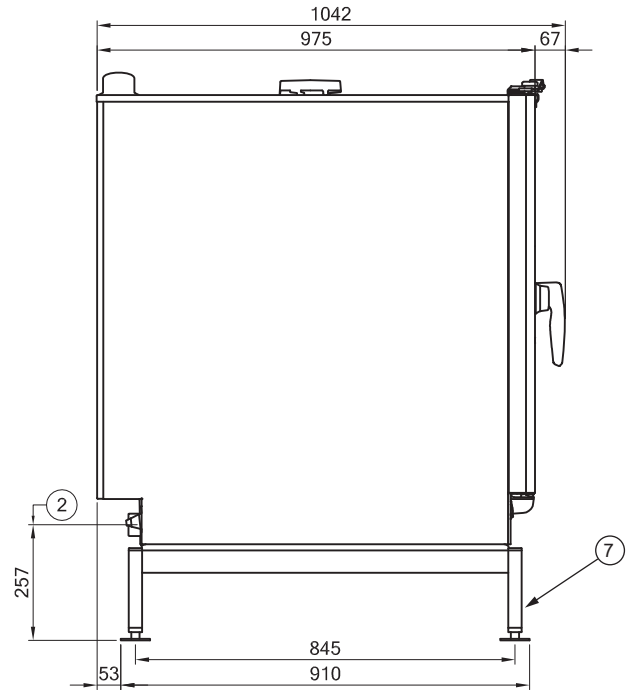

TOP

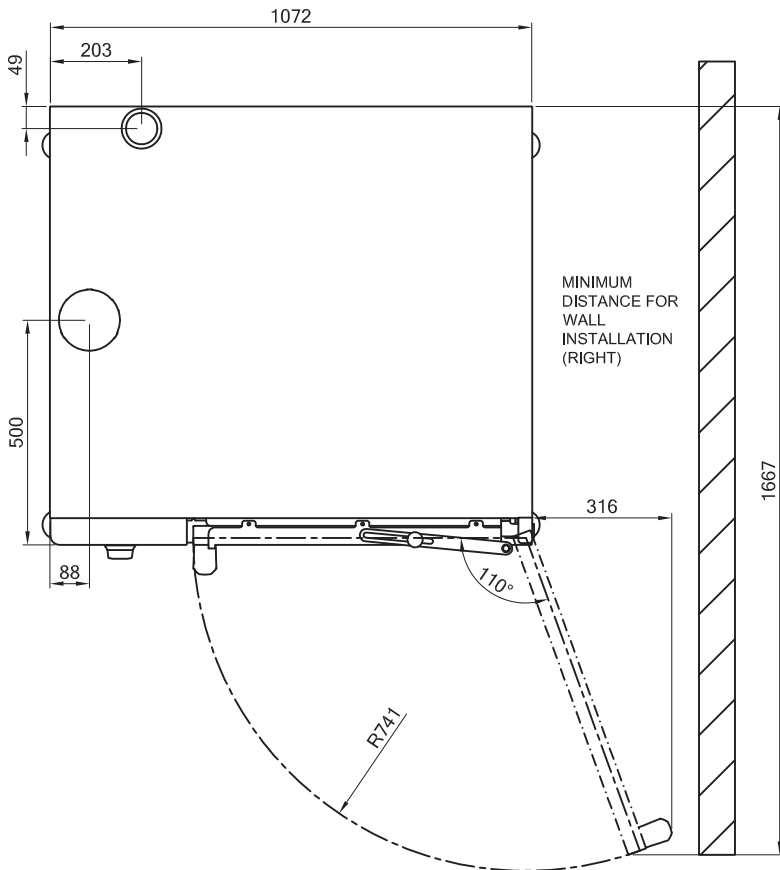

BACK

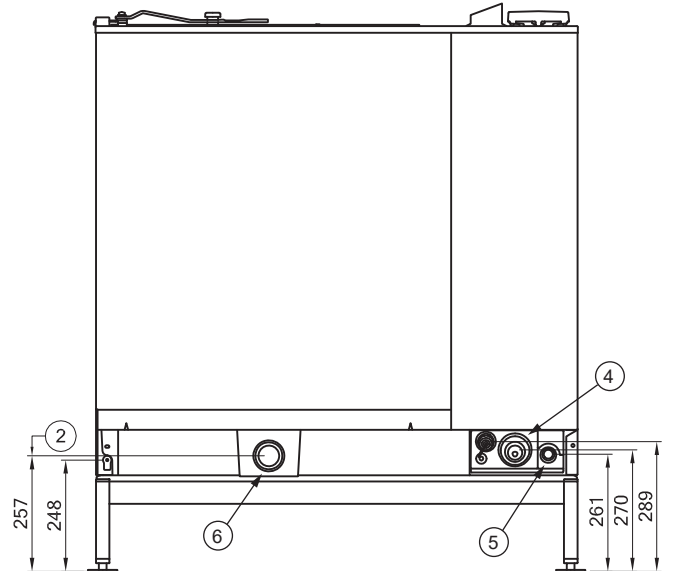

- 1. Height of top rail
- 2. Drain height
- 3. Unit access height
- 4. Power supply
- 5. Water connection
- 6. Drain
- 7. Low stand (optional accessory)

Minimum distance to the device

Minimum distance to all sides

Set up the device taking into account the minimum distances to the wall. The distances depend on the device size, as shown in the table below.

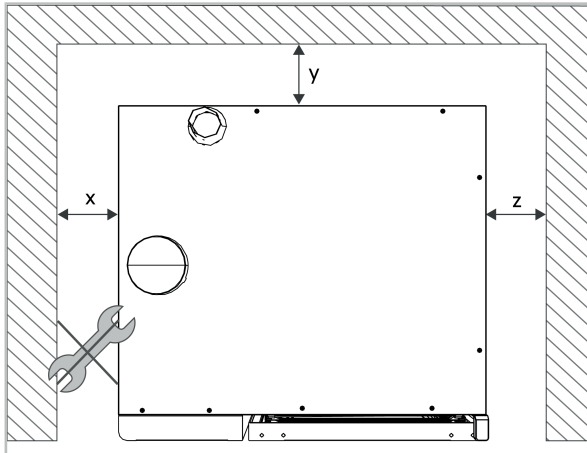

Device size	XS	6 half size	6 full size	10 half size	10 full size	20 half size	20 full size
x (mm)	10	50	50	50	50	500	500
x (inch)	1/2	2	2	2	2	20	20
y (mm)	10	0	0	0	0	0	0
y (inch)	1/2	0	0	0	0	0	0
z (mm)	10	50	50	50	50	50	50
z (inch)	1/2	2	2	2	2	2	2

Recommended distance to the left side of the device

To ensure that there is sufficient space on the left side of the device to carry out service work in the installation area, place the device on the left side at a recommended minimum distance from the wall.

If this distance to the left side of the device is not possible, place the device so that it can be pulled out of the niche for maintenance work.

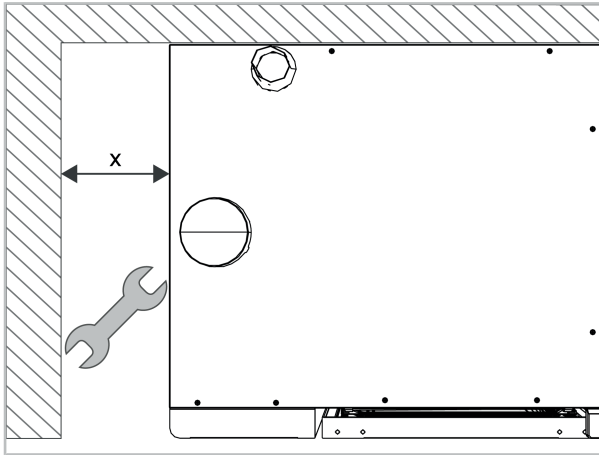

	Distance to the left side of the device
x (mm)	500
x (inch)	20

Recommended distance to the right side of the device

To open the device door at the first grid, place the device on the right with a recommended minimum distance to the wall. The distance depends on the device size, as shown in the table below.

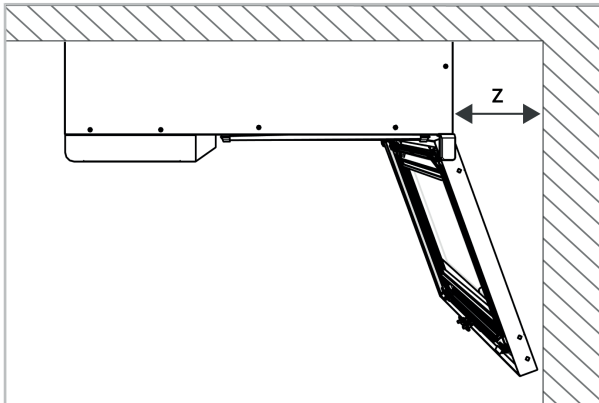

Device size	XS	6 half size	6 full size	10 half size	10 full size	20 half size	20 full size
z (mm)	279	246	316	246	316	268	338
z (inch)	11	10	12 1/2	10	12 1/2	11	13