



COMBI BOILERLESS OVEN SKYLINE PRO 10 GN 2/1

Model: ECOE102C2E0

Article no: 227913

Power supply: 400V 3Ph ~50-60Hz

The new SkyLine Combi Ovens are made to deliver outstanding performance with smart technology and human-centred design.

The Pro models have a digital interface with LED backlight buttons and guided selection. A boilerless steaming function to add and retain moisture for high quality, consistent cooking results. Single sensor core temperature probe included.

Skyline ovens have a wing-shaped handle with ergonomic design and hands-free opening with the elbow, making managing trays simpler. They have a double thermo-glazed door with open frame construction, for a cool outside door panel. A swing hinged easy-release inner glass on door for easy cleaning. Seamless hygienic internal chamber with all rounded corners for easy cleaning and 304 AISI stainless steel construction.

The oven has an OptiFlow air distribution system to achieve maximum performance in cooking evenness and temperature control thanks to the design of the cooking chamber combined with a venting valve and a high precision variable speed fan. The fan has 5-speed levels from 300 to 1500 RPM and reverse rotation for optimal evenness, and the fan stops in less than 5 seconds when the door is opened. The oven also has automatic fast cool down and pre-heat function and reduced power function for customized slow cooking cycles.

MAIN FEATURES

- Digital interface
- Boilerless steaming function
- Single sensor core temperature probe
- OptiFlow air distribution system
- Trolley pitch 63mm with tray stopper
- Double-glass door
- Skyclean automatic cleaning
- Human-centred design with 4-star certification for ergonomics and usability

ECOE102C2E0, 227913

22-01-24 (14:10)

Model Number Specific	ECOE102C2E0
Voltage (V)	400
Phase	3
Frequency (Hz)	50-60
Loading (kW)	35,4
Max Amps in Phase (A)	55,9
Fuse (A)	63
IP Class	X5
Capacity, food load max (kg)	100
Capacity, pans (pcs)	10
Width, net (mm)	1090
Depth, net (mm)	971
Height, net (mm)	1058
Weight, net (kg)	167,5
Weight, gross (kg)	195,5
Volume, net (m3)	1,12
Volume, gross (m3)	1,46
Connection Cable, length (m)	0
Plug type	None
Adapted for container sizes	GN
Automatic cleaning system	Yes
Certifications	CE, Ergocert (Ergonomics Certified)
Cold water inlet temperature (°C)	30
Cold water inlet, diameter (")	3/4
Drain pipe, diameter (mm)	50
Installation, type	Table top model, Floor model
Marine feet	Yes
Noise level <(dB)	70
Other general information	Steam generator: Direct injection. Core probe: single sensor. Fan speed levels: 5. Spray gun: No
Oven, type	Combi
Pan sizes	GN2/1
Temperature, max (°C)	300
Touch control	No
Water pressure, max (Bar)	4,5

Water pressure, min (Bar)	1
----------------------------------	---

Loipart AB (HQ), **Sweden**
Tel. +46 313 920 100, loipart@loipart.se

LMG Finland oy, **Finland**
+358 40 664 6680, lmg@lmg.fi



Loipart USA inc, **USA**
Tel. +1 954 530 5276, loipartusa@loipart.com

Loipart SEA Pte Ltd, **Singapore**
Tel. +65 674 99 100, contact@loipart.sg

Visit us at www.loipart.com

DIMENSIONS

Model: ECOE102B2 Rev. 1
 ECOE102T2
 ECOE102C2
 ECOE102K2

FRONT

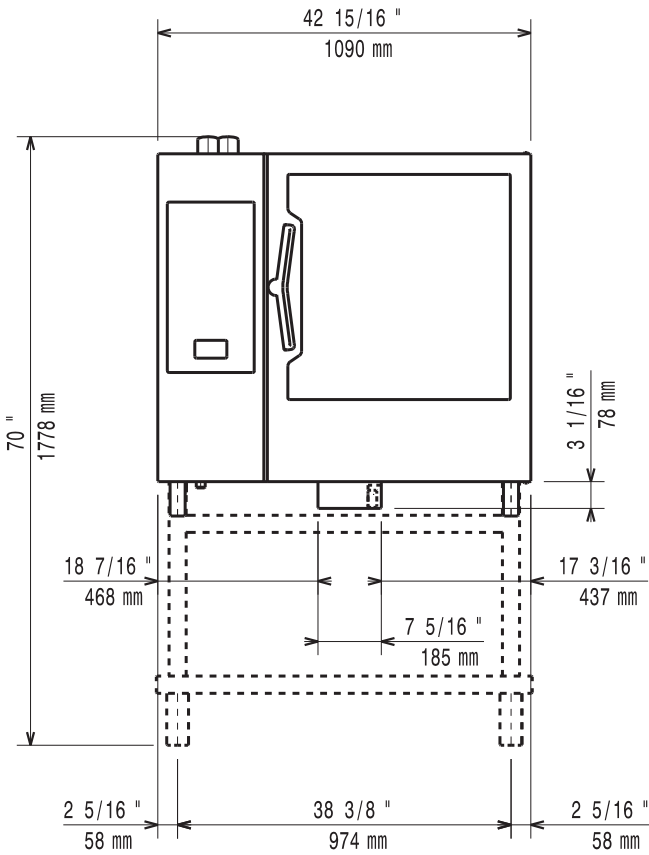

SIDE

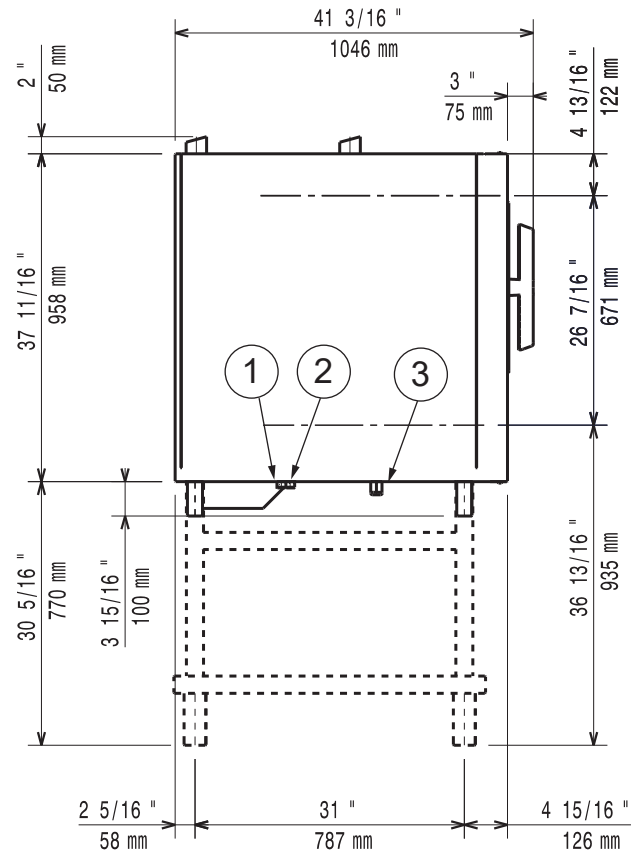

TOP

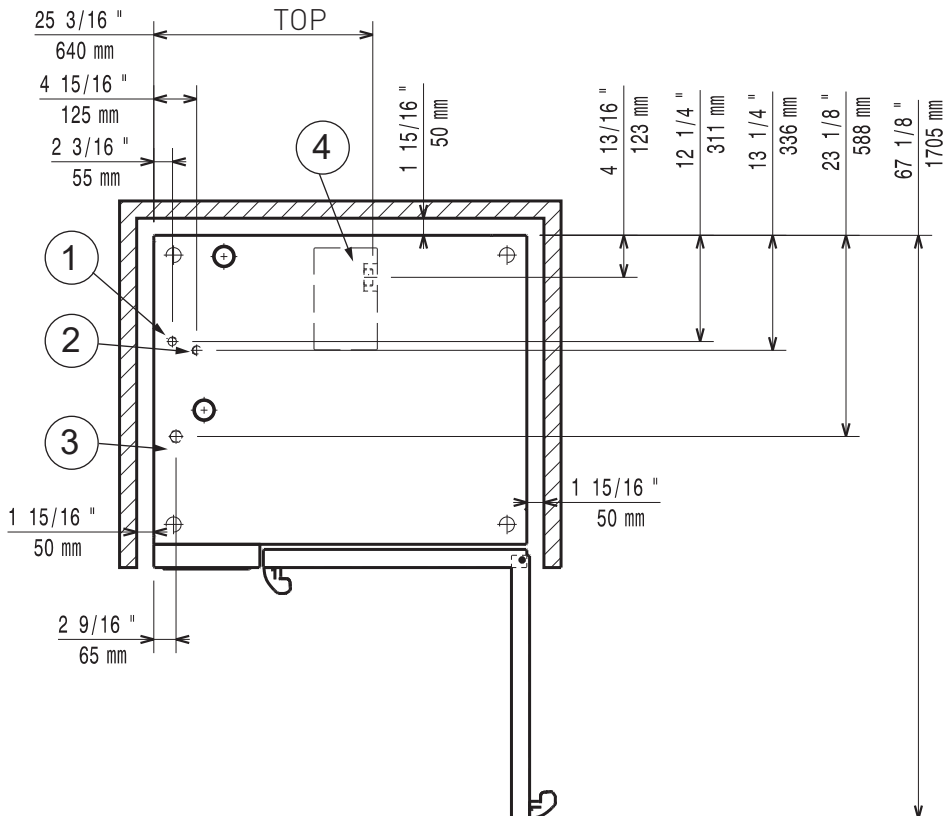

1. Cold water inlet (cleaning system)
2. Cold water inlet (boiler/steam generator)
3. Electrical connection
4. Drain

DETAIL MARINE FOOT

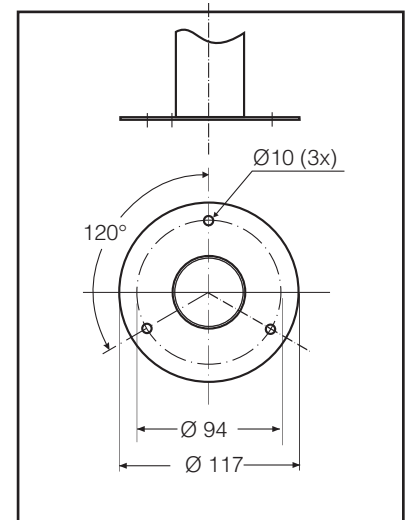

POSITIONING OF MACHINE

normal working	right / left / rear distance 50 mm
work close to heat source	left side distance 350 to 500 mm
service conditions	left side distance 500 mm

- All appliance sides must remain at 50 mm from any surface.

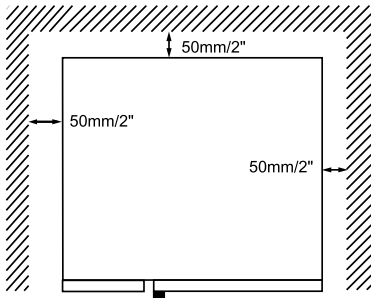

If it's necessary to carry out maintenance works on the appliance, slide it forwards.

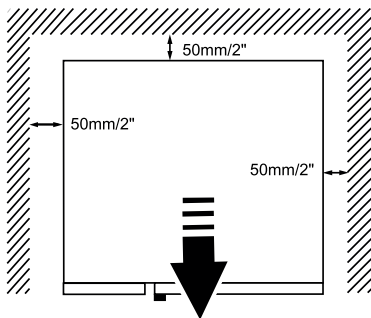

In all models but especially in 20 grids models when possible leave a space of at least 500 mm between the left side of the appliance and the other surfaces to enable maintenance operations.

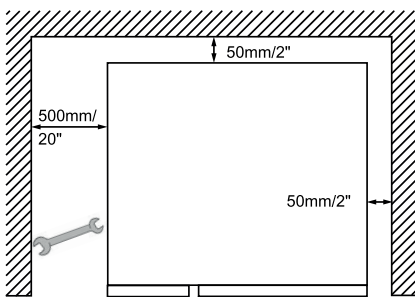

The left gap must be a minimum of 350 mm **if heat sources are acting** on the left side of the appliance.

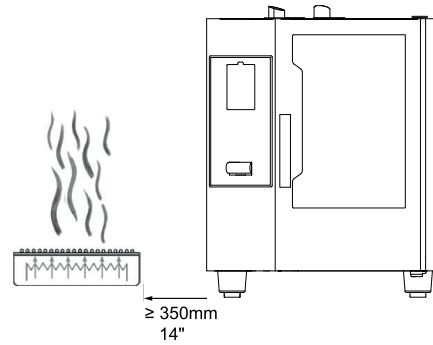

If it is not possible to keep the left side of the appliance a sufficient distance away from heat sources, a heat shield can reduce thermal loads (see accessories catalogue).

If steam from the ventilation pipe cannot be directed into an exhaust hood or a ventilating ceiling, there must be at least 500 mm clearance space above the device.

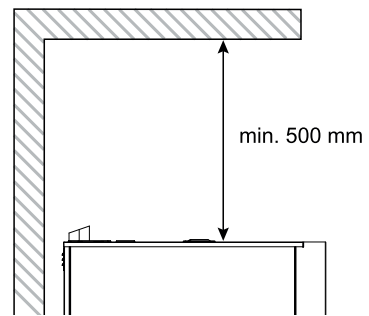

Position the appliance on a flat surface. If necessary, adjust the height of the worktop by means of the adjustable feet (if available).