



## BOILING PAN 150 L, WALLMOUNTED

**Model: PBOT15EV**

**Article no: 587105**

**Power supply: 440V 3Ph ~60Hz**

A boiling pan suitable to boil, steam, poach, braise or simmer all kinds of produce. Ergonomic vessel dimensions, with a large diameter and shallow depth that facilitate stirring and gentle food handling. The pan has a motorized, variable pan tilting and "SOFT STOP." Tilting and pouring speeds can be precisely adjusted, and the pan can be tilted over 90° to facilitate pouring and cleaning operations.

The food is uniformly heated via the base and the side walls of the pan by an indirect heating system. The system uses integrally generated saturated steam at a maximum temperature of 125° C in a jacket with an automatic deaeration system. The safety valve avoids overpressure of the steam in the jacket, and the safety thermostat protects against low water level in the double jacket.

The pan has a touch control panel that can store recipes in the single or multiphase cooking process, with different temperature settings. The built-in temperature sensors enable precise control of the cooking process.

### MAIN FEATURES

- Motorized tilting with soft stop
- IPX6 water-resistant
- Kettle is jacketed up to 134 mm from the upper rim
- Built-in temperature sensor
- USB connection to easily update the software, upload recipes and download HACCP data

PBOT15EV, 587105

16-01-24 (17:32)

Subject to change without notice  
For correct installation, refer to the installation manual

## TECHNICAL DATA

PBOT15EV, 587105, 16-01-24 (17:32)

<b>Model Number Specific</b>	PBOT15EV
<b>Voltage (V)</b>	440
<b>Phase</b>	3
<b>Frequency (Hz)</b>	60
<b>Loading (kW)</b>	24
<b>Max Amps in Phase (A)</b>	31,8
<b>IP Class</b>	X6
<b>Capacity (L)</b>	150
<b>Width, net (mm)</b>	900
<b>Depth, net (mm)</b>	1300
<b>Height, net (mm)</b>	400
<b>Weight, net (kg)</b>	260
<b>Weight, gross (kg)</b>	273
<b>Volume, net (m3)</b>	0,47
<b>Volume, gross (m3)</b>	0,61
<b>Connection Cable, length (m)</b>	2
<b>Plug type</b>	None
<b>Cold water inlet, diameter (")</b>	G 1/2
<b>Connection height, electric (mm)</b>	450
<b>Connection height, water (mm)</b>	395
<b>Hot water inlet, diameter (")</b>	G 1/2
<b>Installation, type</b>	Wall mounted model
<b>Marine feet</b>	No
<b>Noise level &lt;(dB)</b>	70
<b>Pressure (Bar)</b>	0,1
<b>Pressure, max (Bar)</b>	1,5
<b>Tilting, type</b>	Electric
<b>USPH</b>	Yes
<b>Water pressure, max (Bar)</b>	6
<b>Water pressure, min (Bar)</b>	1,7

## INCLUDED IN DELIVERY

1 pc of Emergency stop button - factory fitted.

Loipart AB (HQ), Sweden  
Tel. +46 313 920 100, loipart@loipart.se

LMG Finland oy, Finland  
+358 40 664 6680, lmg@lmg.fi



Loipart USA inc, USA  
Tel. +1 954 530 5276, loipartusa@loipart.com

Loipart SEA Pte Ltd, Singapore  
Tel. +65 674 99 100, contact@loipart.sg

Visit us at [www.loipart.com](http://www.loipart.com)

## DIMENSIONS

### WALL INSTALLATION POINTS

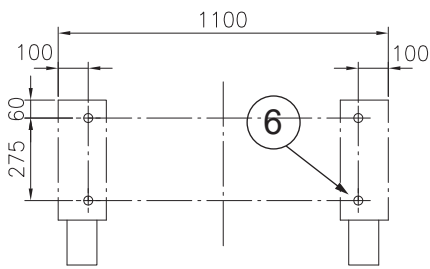

### Wall installation

Before you start, prepare the mounting holes in the wall according to the specifications in the mounting diagram.

1. Use the supplied wall anchors with the threaded rods **A**. The holes must have a diameter of 18 mm [0,71"] and a minimum depth of 145 mm [5,71"].  
Wall anchors with long threaded rods must be positioned at the top, those with short rods must be positioned at the bottom.
2. Clean the hole after drilling.
3. Tighten wall anchor nuts **B** to a torque of 80 Nm.
4. Then fit nuts **C** and washers **G** and screw in the supporting bracket **E** at a distance of 30 mm [1,18"].
5. Align all support brackets **E** correctly.
6. Level the set screws **F** in the support brackets **E**.
7. Lift the unit on the wall anchor threaded bolts and level it using a spirit level.
8. Finally fix it with washers **G** and nuts **C** and fit the lock nut **D**.

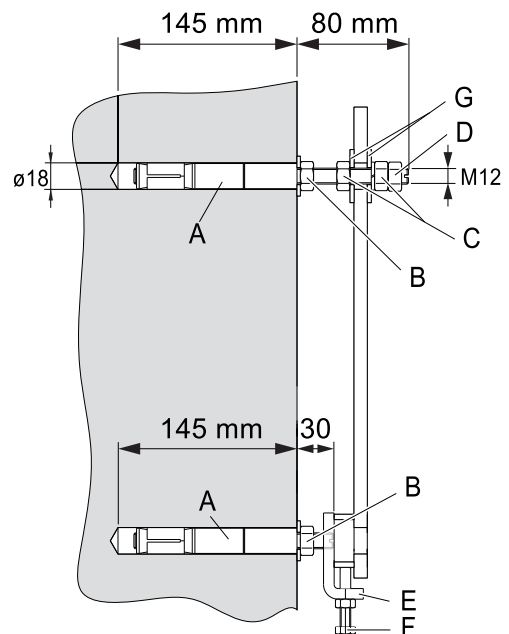

# DIMENSIONS

Model: PBOT15EV Rev. 1  
PBOT15RV

FRONT

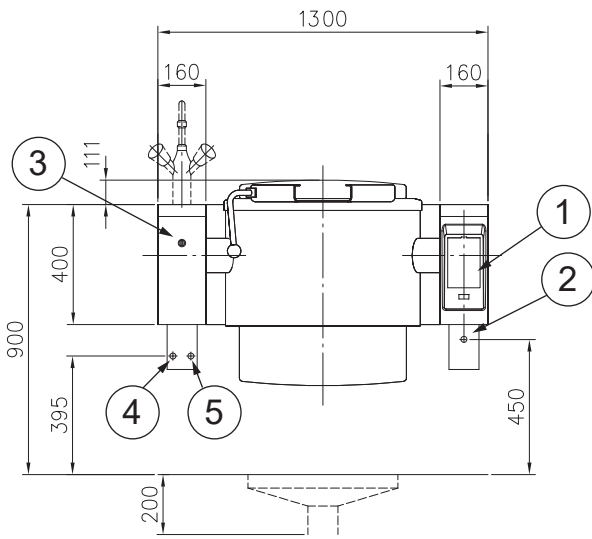

SIDE

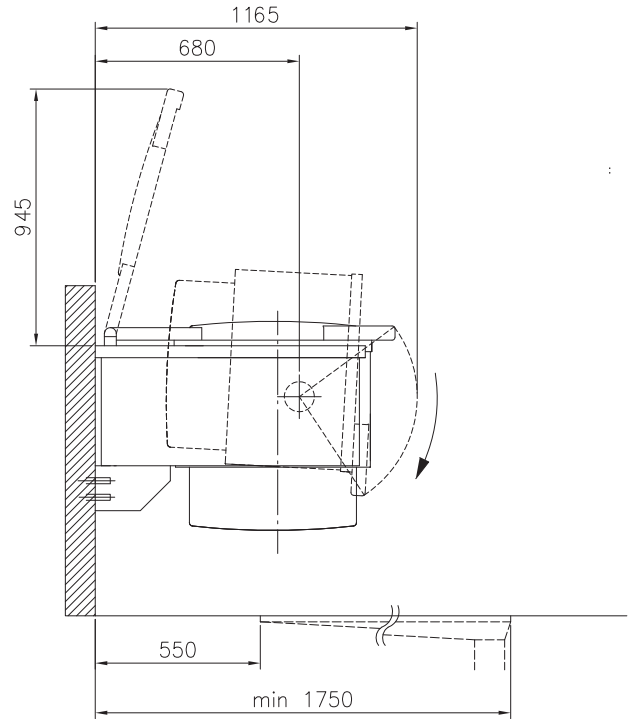

TOP

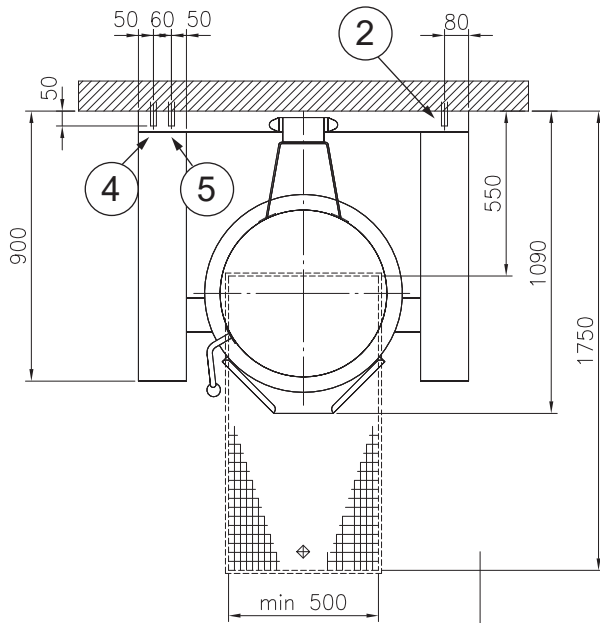

1. Control panel
2. Electrical connection
3. Motor tilting control
4. Hot water connection, G1/2" (NW15)
5. Cold water connection, G1/2" (NW15)
6. Wall attachment points