



BOILING PAN 100L

Model: L9BSEHIPF5

Article no: 393705

Power supply: 440V 3Ph ~60Hz

The L900 boiling pan is suitable for cooking, sauté, or poaching all kinds of food. The unit features high-efficiency heating elements (9.4 kW) with energy control and a temperature limiter. The food is uniformly heated in the base and side walls of the kettle by an indirect heating system that uses integrally generated saturated steam at a temperature of 110°C in the jacket.

The model has a pressed cooking vessel and lid in 316 AISI Stainless steel. The external valve allows a manual evacuation of excess air accumulated in the jacket during the heating phase. It also has a large drain tap that enables precise portioning of the discharged food, especially in small quantities.

With ergonomics in mind, the vessel has a unique ratio diameter and depth to facilitate stirring and gentle food handling. The discharge tube and tap are easy to clean from the outside and smooth large surfaces with easy access for cleaning.

MAIN FEATURES

- High-efficiency heating elements (9.4 kW)
- Appliance is IPX5 water resistance certified
- Firmly fitting cover to reduce cooking time and save energy
- Ergonomic and easy-to-clean model
- Solenoid valve to refill with hot and cold water
- Right-angled side edges to allow flush fitting joints between units, eliminating gaps and possible dirt traps
- Exterior panels in stainless steel with Scotch Brite finish
- One piece pressed 1.5 mm work top in Stainless steel

L9BSEHIPF5, 393705

16-01-24 (17:20)

Subject to change without notice
For correct installation, refer to the installation manual

TECHNICAL DATA

L9BSEHIPF5, 393705, 16-01-24 (17:20)

Model Number Specific	L9BSEHIPF5
Voltage (V)	440
Phase	3
Frequency (Hz)	60
Loading (kW)	21,5
IP Class	X5
Capacity (L)	100
Width, net (mm)	800
Depth, net (mm)	930
Height, net (mm)	900
Weight, net (kg)	135
Weight, gross (kg)	160
Volume, net (m3)	0,67
Volume, gross (m3)	0,87
Connection Cable, length (m)	0
Plug type	None
Certifications	CE
Cold water inlet, diameter (")	3/4
Drain pipe, diameter (")	2
Front rail, included	No
Hot water inlet, diameter (")	3/4
Installation, type	Floor model
Marine feet	Yes
Noise level <(dB)	70

Loipart AB (HQ), **Sweden**
Tel. +46 313 920 100, loipart@loipart.se

LMG Finland oy, **Finland**
+358 40 664 6680, lmg@lmg.fi



Loipart USA inc, **USA**
Tel. +1 954 530 5276, loipartusa@loipart.com

Loipart SEA Pte Ltd, **Singapore**
Tel. +65 674 99 100, contact@loipart.sg

Visit us at www.loipart.com

DIMENSIONS

Model: L9BSEHIPF5 Rev. 1

FRONT

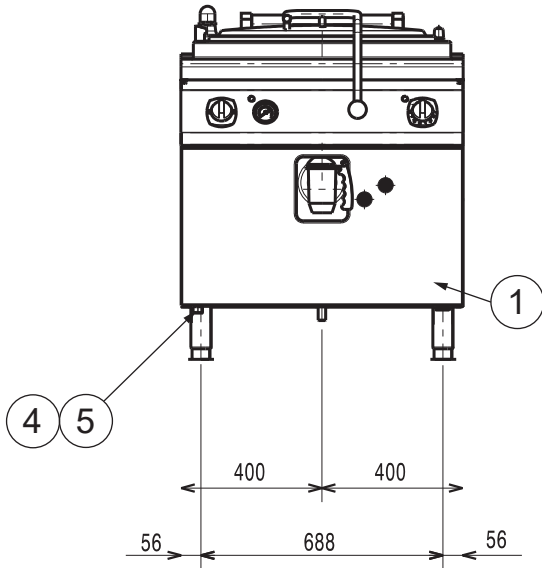

SIDE

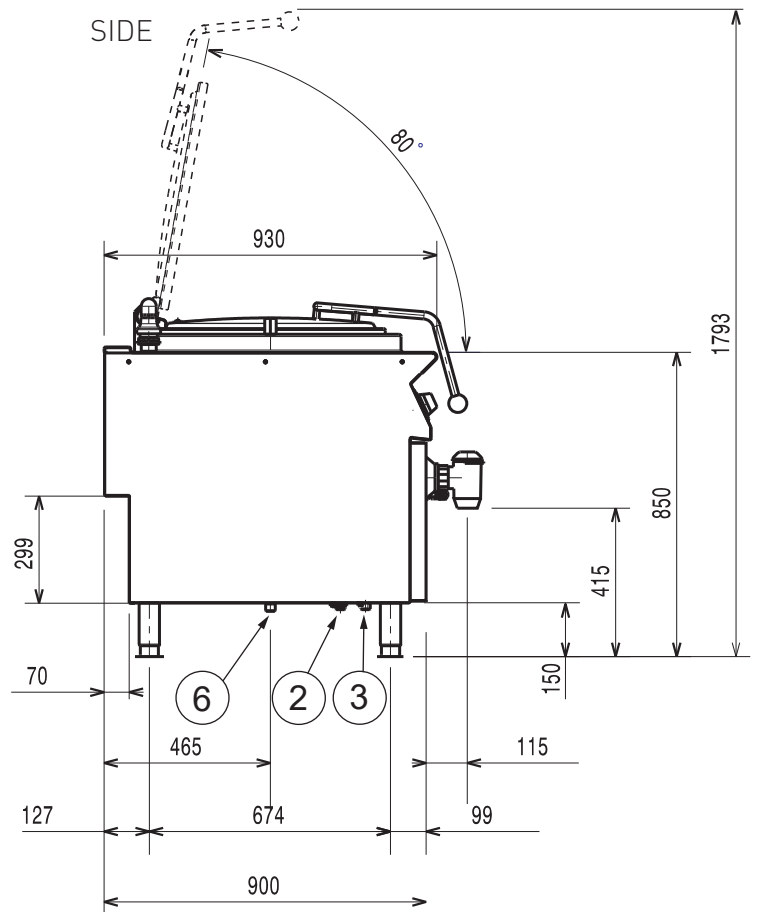

TOP

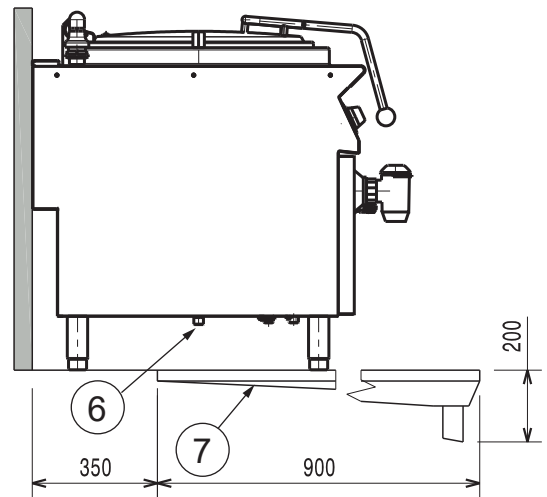
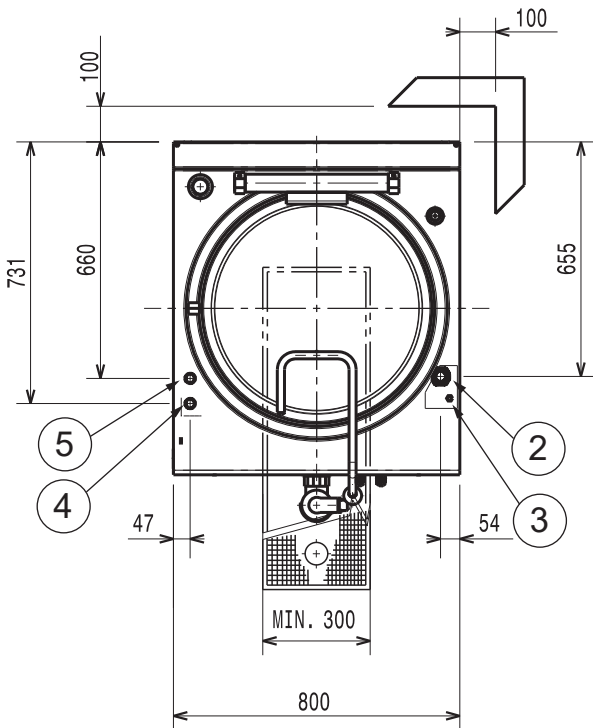

DETAIL MARINE FOOT

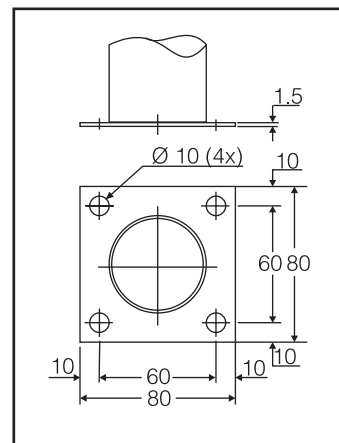

1. Electrical connection point (terminal board) located behind the front cover
2. Electrical supply inlet
3. Equipotential screw
4. Cold water inlet 3/4"
5. Hot water inlet 3/4"
6. Drain 2"
7. Floor outlet and gutter