



BAKING OVEN, 4-DECK

Model: DC-42

Article no: 1693131501

Power supply: 440V 3Ph ~60Hz

This commercial bakery line of baking ovens is of the most heavy duty execution. The exterior is made of polished stainless steel, with doors fitted with tempered glass. The oven chamber, with effective double working halogen lighting, is made of heavy duty tempered steel. Stainless steel front maintains low temperature and is easy to keep clean. The inside is built completely in stainless materials to ensure a long service-life, simple cleaning, and low maintenance costs. Oven sections are provided with heating elements specially selected for reliability and rapid response.

The baking ovens are available in 2- or 3-tray deck versions as combination of 2, 3 or 4 oven sections. Each oven section can be individually controlled with separate settings of the top, bottom and front heat which gives full control in the baking process. These features in combination with a very efficient insulation, result in a perfect baking result at minimum energy consumption. The baking oven can be supplied with an underbuild prover, available in 2 heights. Also the prover is made of stainless steel with glass doors and interior lighting. It has a builtin fan for even humidity distribution. For further specifications of the various models and optional extras, please see following pages.

MAIN FEATURES

- Commercial Bakery Line
- Advanced Heating Technology
- Digital Control Panel
- Easy to Operate and Maintain
- Six Models
- Optional Prover
- Wide Range of Optional Extras

DC-42, 1693131501
22-01-24 (14:03)

TECHNICAL DATA

DC-42, 1693131501, 22-01-24 (14:03)

Model Number Specific	DC-42
Voltage (V)	440
Phase	3
Frequency (Hz)	60
Loading (kW)	27,6
Width, net (mm)	1390
Depth, net (mm)	1070
Height, net (mm)	2020
Weight, net (kg)	570
Weight, gross (kg)	670
Volume, net (m3)	4,1
Volume, gross (m3)	5,33
Baking decks (pcs)	4
Installation, type	Floor model
Oven, type	Baking
USPH	Yes

Loipart AB (HQ), **Sweden**
Tel. +46 313 920 100, loipart@loipart.se

LMG Finland oy, **Finland**
+358 40 664 6680, lmg@lmg.fi



Loipart USA inc, **USA**
Tel. +1 954 530 5276, loipartusa@loipart.com

Loipart SEA Pte Ltd, **Singapore**
Tel. +65 674 99 100, contact@loipart.sg

Visit us at www.loipart.com

DIMENSIONS

Model: 169313 Rev. 1

FRONT

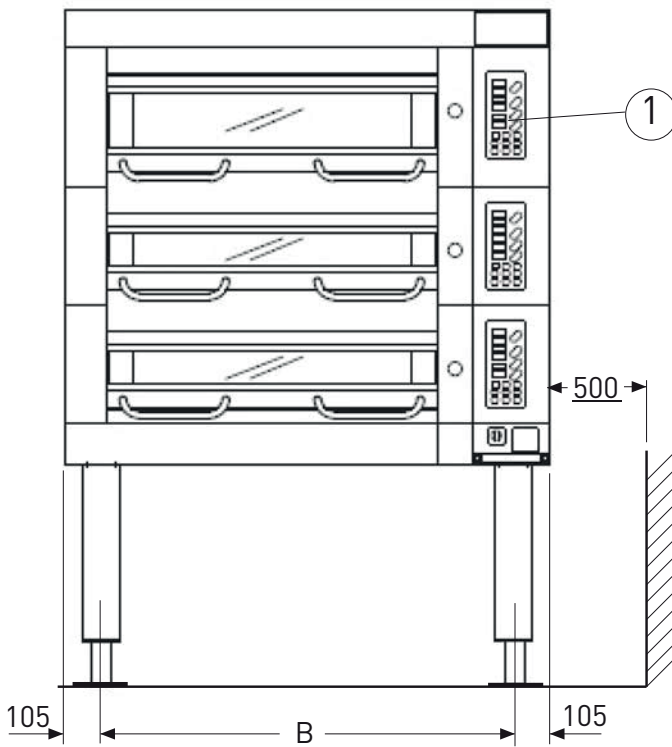

SIDE

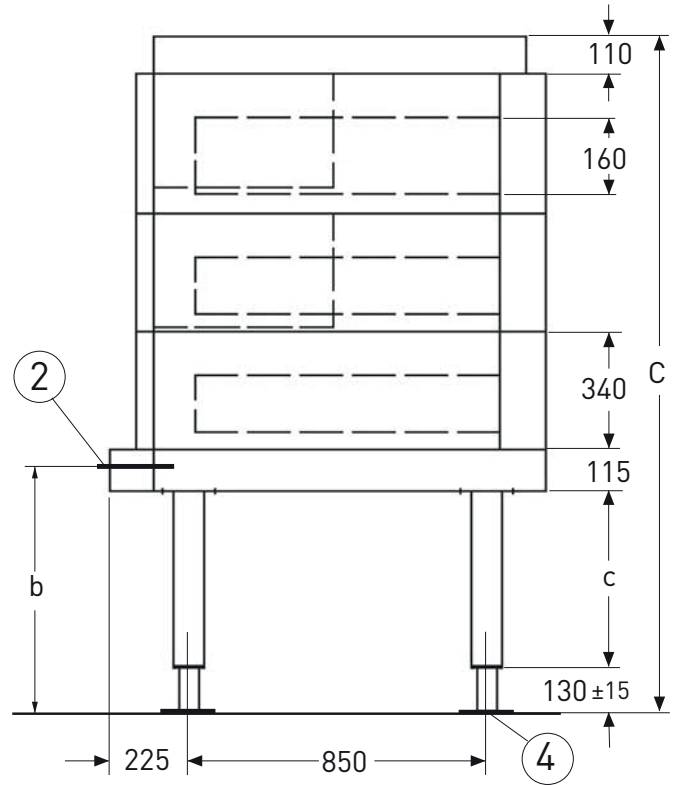

TOP

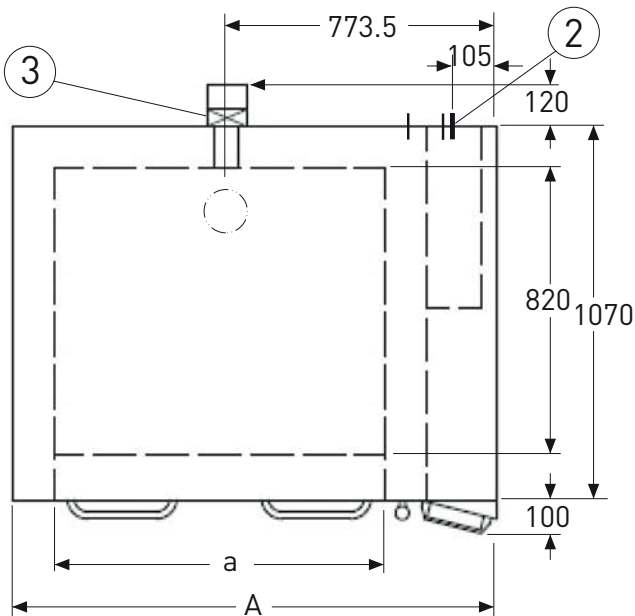

- 1. Digital control panel
- 2. Electrical connection
- 3. Oven exhaust 50 x 115 mm
- 4. Marine foot

Type DC 42 (4 decks, 2 plates/deck)

A	a	B	b	C	c
1390	950	1180	622	2020	300

DETAIL MARINE FEET

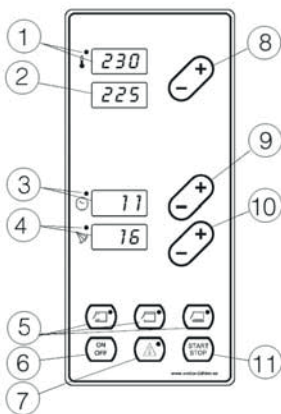
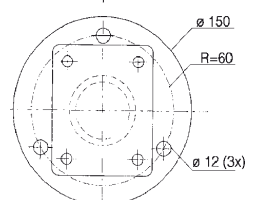
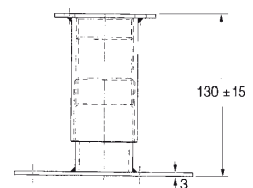

- 1. Temperature-actual value
- 2. Temperature -desired value
- 3. Baking time
- 4. Steam time
- 5. Heat control buttons
- 6. On/off button for panel
- 7. Alarm button
- 8. Increase/decrease button -temperature / power distribution
- 9. Increase/decrease button -baking time
- 10. Increase/decrease button -steam time
- 11. Start/stop button for baking